

# ZONE WIRELESS 2 ES FOR BUSINESS (WITH RECEIVER VERSION)

Setup Guide  
Guide d'installation



## CONTENTS

English . . . . . 3

Français . . . . . 15

Español . . . . . 27

Português . . . . . 39

繁體中文 . . . . . 51

한국어 . . . . . 63

# KNOW YOUR PRODUCT

## FRONT VIEW

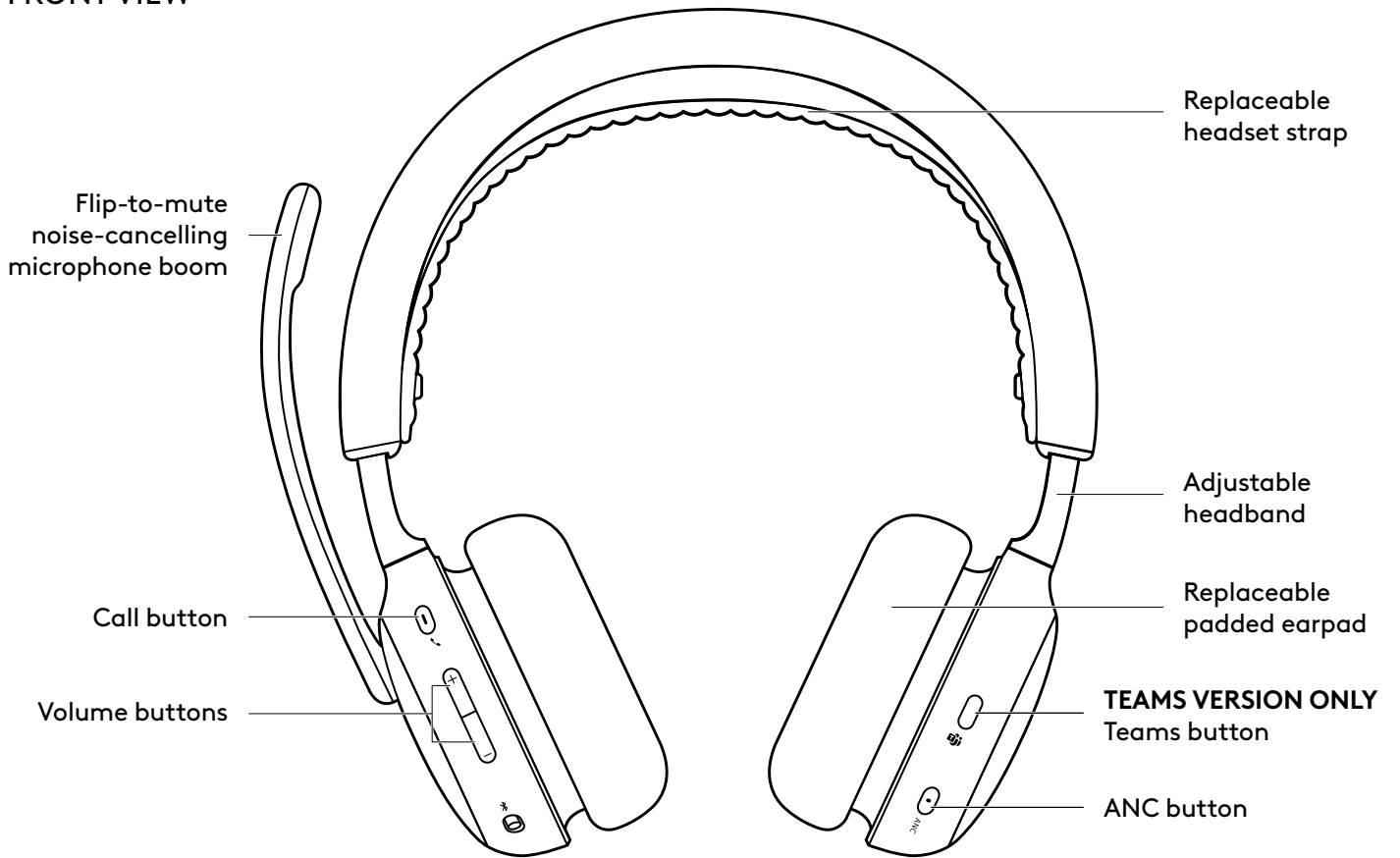

## BOTTOM VIEW

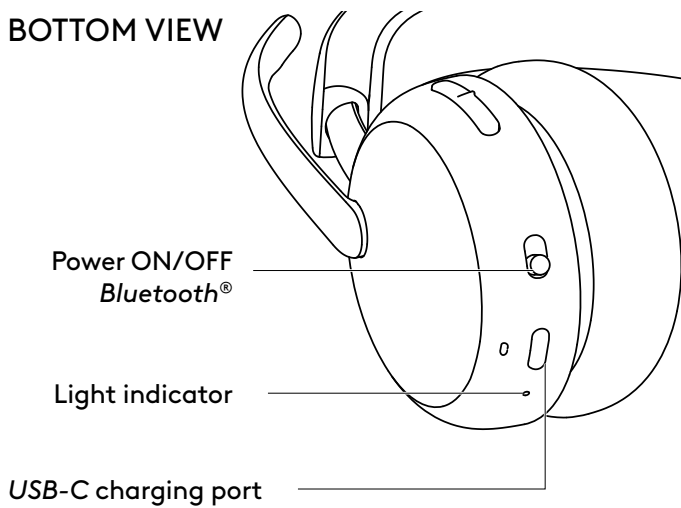

## USB RECEIVER AND ADAPTER

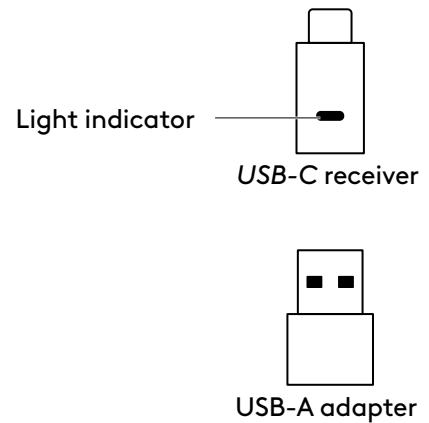

## WHAT'S IN THE BOX

1. Headset
2. *USB-C* receiver
3. *USB-A* adapter
4. *USB-C* to *C* charging cable
5. Travel bag
6. User documentation

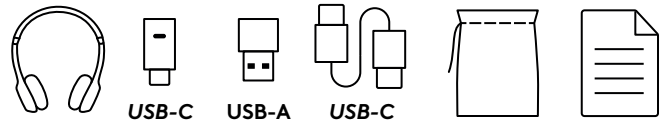

## POWER ON/OFF

1. Slide power switch to the center.
2. Once powered on, the light indicator turns white.
3. To power off, slide power switch to the power icon.

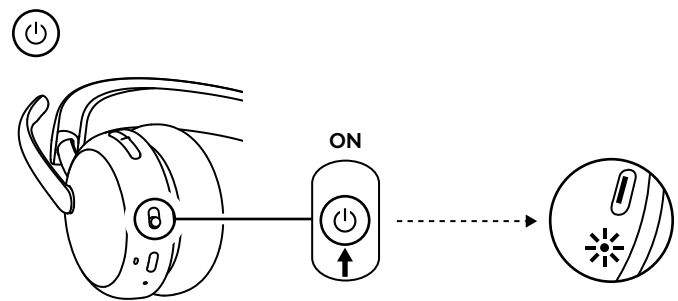

## PAIRING VIA USB RECEIVER

1. **USB-C**  
Insert the receiver into the computer *USB-C* port.  
**USB-A**  
Insert the *USB-C* receiver into the *USB-A* adapter. Then insert the adapter into the computer *USB-A* port.
2. The headset is already paired to the receiver it ships with. Just power on the headset. Once successfully paired, the light indicator on the receiver will remain solid white. The light indicator on the headset will turn solid white.
3. Make sure "Logi Zone Wireless 2 ES B2B" is selected on the computer sound setting.

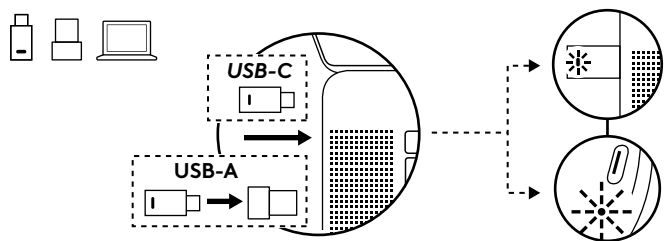

## PAIRING VIA BLUETOOTH®

1. Slide power switch to the *Bluetooth*® icon and hold for 2 seconds. The light indicator will flash white rapidly.
2. Open *Bluetooth*® settings on your device.
3. Select "Logi Zone Wireless 2 ES B2B" in discoverable devices.
4. Once successfully paired, the light indicator will turn solid white.

### Tip (when using Windows 10 only):

When the headset is paired to the laptop, if needed, go to the sound setting and select "Logi Zone Wireless 2 ES B2B Stereo" for the best music quality and select "Logi Zone Wireless 2 ES B2B Hands-Free" for calls.

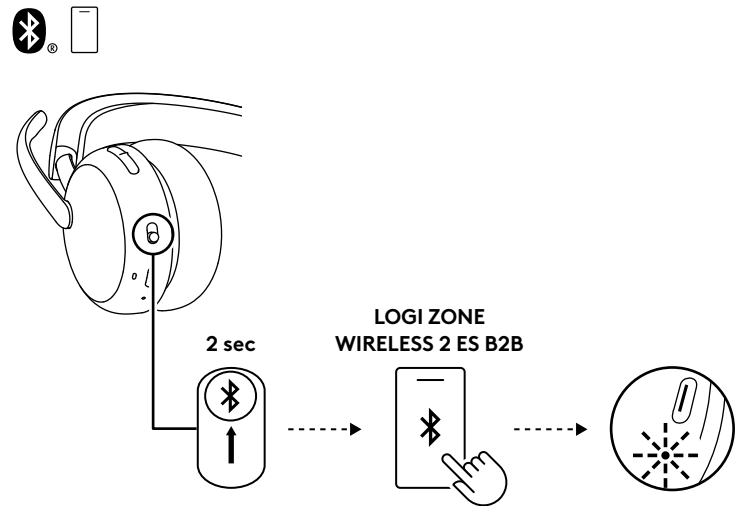

## ADJUSTING HEADSET

1. Adjust the headset by sliding earcups up and down the headband.
2. Swivel earcups to fit on your ear.
3. It may be easier to adjust the headset on your head. Move the earcups up and down the headband until they sit comfortably on your ears.

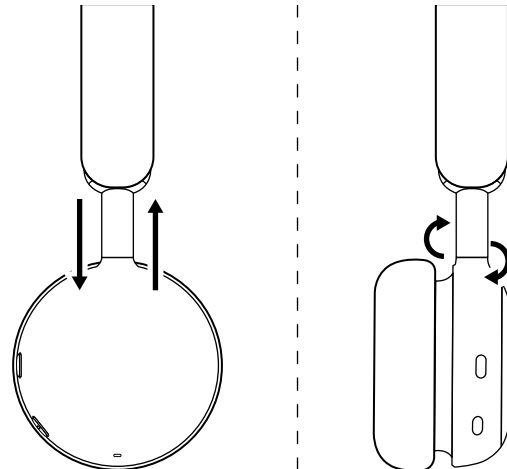

## ADJUSTING THE MICROPHONE BOOM

The microphone boom rotates 270 degrees. Wear it on either the left or right side. The audio channel will switch automatically, depending on the direction you are wearing the microphone.

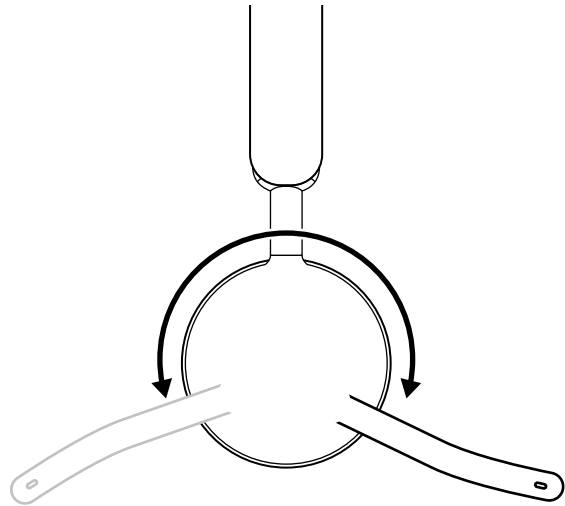

Mic boom should be placed close or next to your mouth, aligned with the corner of the mouth.

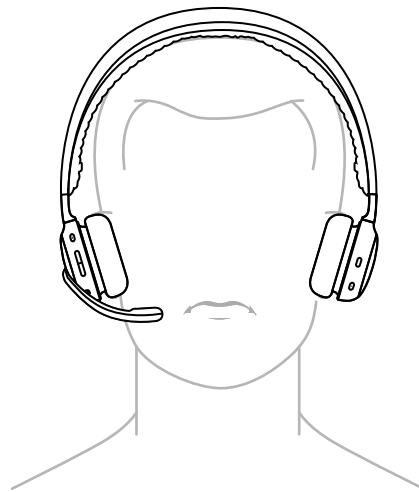

## CHARGING

The headset automatically powers off when left idle.

Sleep timer can be changed in Logi Tune app.

The headset indicator light will turn RED when the battery is low.

### CHARGING VIA USB CABLE

1. Plug one end of the cable to the *USB-C* port on the bottom of the earcup and the other end into the *USB-C* charging port on your computer, dock, or a power adapter.
2. Indicator light will be a breathing white light for charging.
3. Indicator light will be solid white when fully charged.
  - 2 hours of charging fully charges the battery.
  - 5 minutes will give you up to 1 hour of talk time.\*
4. The headset can be used with a receiver and *Bluetooth*® paired while charging. It can also be used as a corded headset with the *USB-C* cable connected while the headset is powered off.

\*Battery life may vary based on environmental and computing conditions.

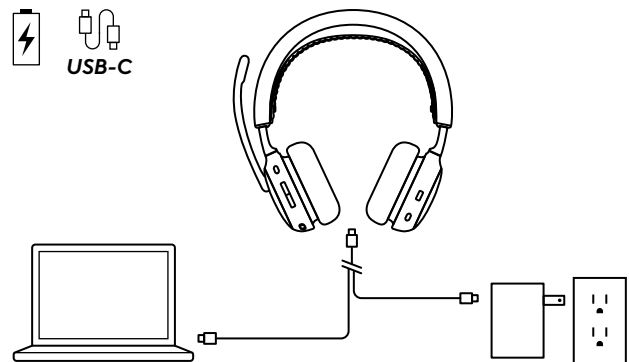

## HEADSET CONTROLS

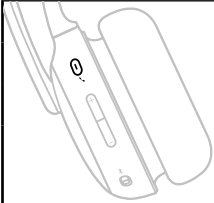
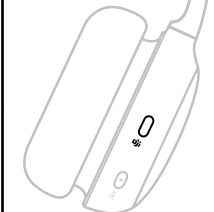
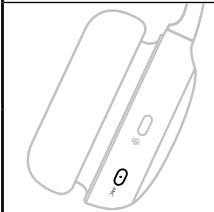
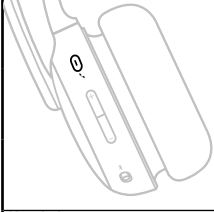
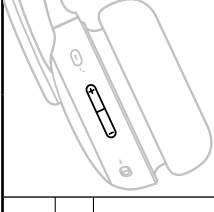
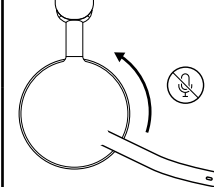
Button	Usage		Action
	<b>Call controls</b>	Answer / End call	Short press
		Resume on-hold call	
	<b>Voice assistance</b>	Trigger voice assistant (when there is no call activity)	2 seconds press
	<b>Teams call controls (Teams version only)</b>	Teams activities	Short press
			2 seconds press
	<b>ANC controls</b>	Toggle between ANC and Transparency On	Short press
		ANC off	2 seconds press
	<b>Media controls (Enable with Logi Tune)</b>	Play / Pause	Short press
		Next track	Double press
		Previous track	Triple press
	<b>Volume controls</b>	Volume up	Short press up
		Volume down	Short press down
	<b>Mute</b>	Mute on	Mic boom flip up
		Mute off	Mic boom flip down

**Note:**

- Teams activities are only functional when Teams is running on an unlocked computer.
- Media control functionality depends on the type of application. It can only be set up through the Logi Tune app.
- Call activities are always the first priority over media streaming. When two devices are connected, the *Bluetooth*<sup>®</sup> connection will be prioritized over the receiver. When two *Bluetooth*<sup>®</sup> devices are connected, the last active device will take a priority over the other. And the priority between two *Bluetooth*<sup>®</sup> devices can be customized on Logi Tune app under Connected devices.
- To know more about Teams button, visit the *Microsoft Support* page: Use the *Microsoft Teams* button on your certified Teams device.
- Voice prompts indicate when the mic is mute on/off.

**Tip:** ANC can be customized on Logi Tune app.

## ACTIVE NOISE CANCELLATION (ANC)

ANC blocks out the noise around you to help you concentrate on the task at hand.

- Press the ANC button on the side of the earcup to toggle between ANC and Transparency mode.
- There will be voice prompts when switching between modes.

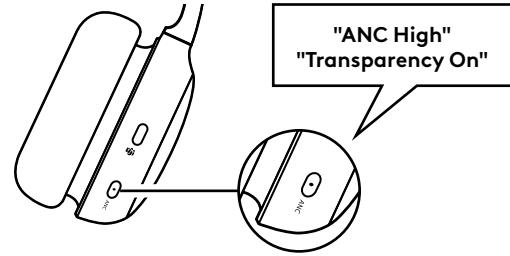

**Note:** ANC button can be customized to cycle through up to 5 different modes on Logi Tune app.

## HEADSET LIGHT INDICATOR

Light		Status
White	Solid	Power on
		Connected to a device
		Battery fully charged
	Pulsing	Battery charging
	Flashing	Incoming call
Bluetooth® pairing mode		
Red	Blinking	Low battery
	Solid	Mute on
Purple and White	Blinking	Headset firmware updating

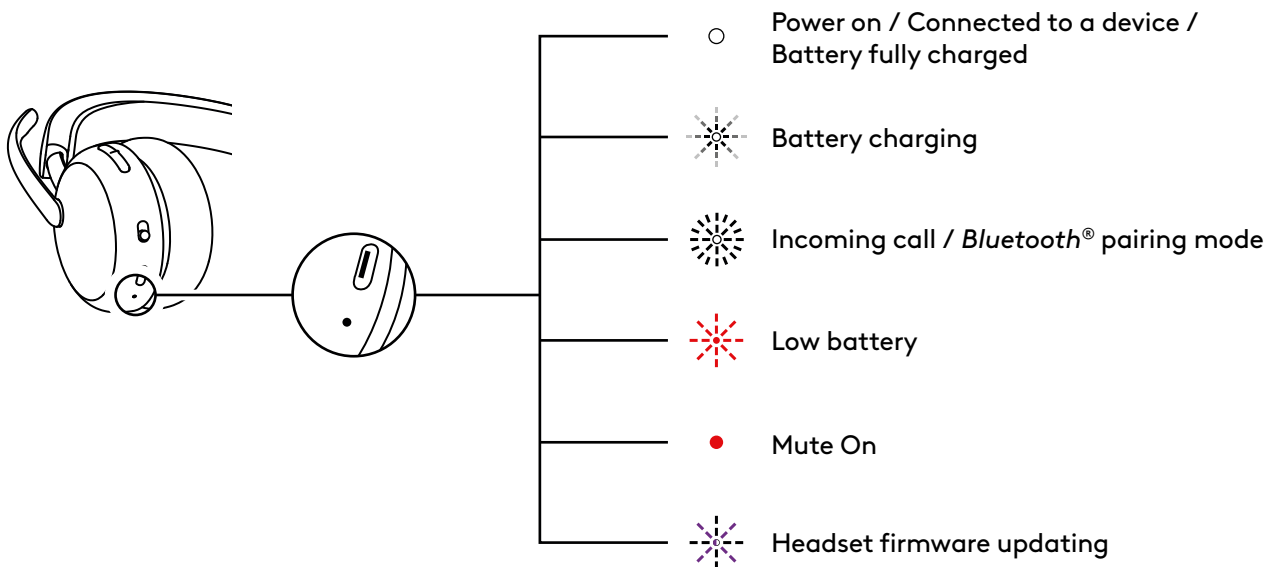

## RECEIVER INDICATOR LIGHT

Microsoft Teams version		
	Light	Status
White	Solid	Connected
	Repeat flashing on and off	Incoming call
Purple	Solid	Connected to Teams
	Pulsing	Connecting to Teams / Teams notifications
	Flashing 3 times and off	Not connected to Teams
	Flashing for 10 seconds and off	Failed to connect to Teams
Red	Solid	Mute on
Blue	Flashing	Pairing

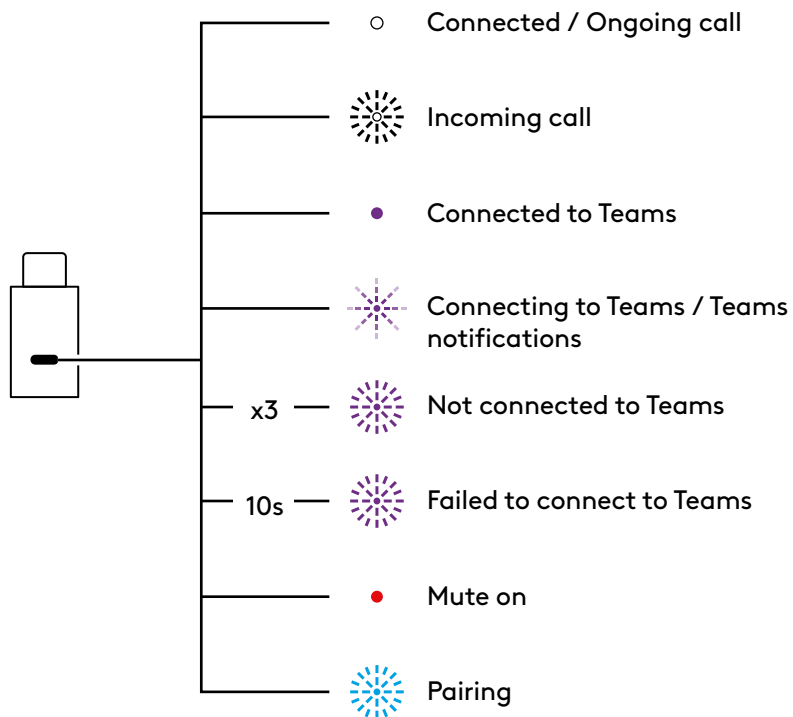

UC version		
Light		Status
White	Solid	Connected
		Ongoing call
	Repeat flashing on and off	Incoming call
Red	Solid	Mute on
Blue	Flashing	Pairing



### AUDIO OVER USB (DENSITY-FRIENDLY)

If your audio is unstable during a call because there are too many wireless devices nearby (high density), the headset can be used as a corded headset.

1. Turn off the headset.
2. Connect the headset to the USB cable provided. And plug the other side of the *USB-C* cable into the *USB-C* port on your computer.
3. Make sure "Logi Zone Wireless 2 ES B2B-USB" is selected on the audio device setting.

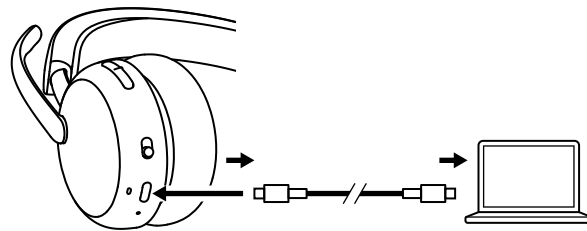

**Note:** Headset would be charged during this mode. Button controls may not be available in this mode.

## LOGI TUNE

Logi Tune helps boost your headset performance with periodic software and firmware updates.

Learn more and download Logi Tune at [logitech.com/tune](https://logitech.com/tune), the *Apple App Store* or *Google Play* store.



## ADJUSTING SIDETONE

Sidetone lets you hear your own voice during conversations so you are aware of how loud you are talking. In Logi Tune app, select the sidetone feature, and adjust the dial accordingly.

- A higher number means you hear more external sound.
- A lower number means you hear less external sound.

## AUTO SLEEP TIMER

By default, your headset will automatically power off when not in use for 30 mins. Adjust the sleep timer in the Logi Tune app.

## MIC EQ

Customize Mic EQ in Logi Tune to adjust your voice to sound brighter or deeper.

## HEARING PROTECTION

Zone Wireless 2 ES for Business provides three types of protection to help you hear safely.

**Peak limiting:** Audio volume is always limited at 100dBA to prevent hearing damages.

**Anti-startle protection:** It eliminates sudden audio spikes to avoid acoustic shocks as per Australian G616 guideline. This can be enabled on the Logi Tune app and applies to call activities only.

**Noise exposure over time:** It protects your ears from the noise exposure over an 8-hour period with a limit up to 85dBA as per Australian G616 guideline. This can be enabled on the Logi Tune app and applies to call activities only.

## UPDATE YOUR HEADSET

It is recommended to update both your headset and receiver. To do so, download Logi Tune from [logitech.com/tune](https://logitech.com/tune) and check for available firmware updates.

**Note:** Turn off and on the headset after the update is completed to make sure it is successfully done.

## RECONNECT YOUR HEADSET

In case the headset is disconnected to the receiver, you can reconnect your headset via Logi Tune.

1. Plug *USB-C* receiver or *USB-A* adapter with the *USB-C* receiver into the computer *USB* port.
2. Power on the headset by sliding the power switch to the center.
3. Open Logi Tune Desktop on your computer.
4. Select "Zone Receiver" from the dashboard.
5. Wait while it is looking for the previously connected headset.
6. If no headset is shown as connected to the receiver, click "Pair headset".
7. Enter pairing mode on the headset by sliding the power switch to the *Bluetooth*<sup>®</sup> icon and holding it for 2 seconds. The light indicator will flash white rapidly.
8. Once successfully paired, the light indicator on the receiver and on the headset will turn solid white.

## RESET YOUR HEADSET

To reset your headset back to its original state, power headset on, long press the volume up button and slide power button to the pairing mode for 5 seconds. The headset is successfully reset when the headset light indicator blinks fast in red and white 3 times and turns off.

## DIMENSIONS

### Headset:

Height x Width x Depth:  
185.2 x 183.6 x 73.0 mm

### Weight:

212 g

### Receiver:

Height x Width x Depth:  
26.8 x 12.4 x 6.2 mm

### Adapter:

Height x Width x Depth:  
24.5 x 15.4 x 8.7 mm

## SYSTEM REQUIREMENTS

Works with common calling applications across almost all platforms and operating systems. Works with *Windows*, *Mac*, or *Chrome*-based computer via *USB-C*, *USB-A*, *Bluetooth*<sup>®</sup> and *iOS* or *Android Bluetooth*<sup>®</sup> enabled devices.

## TECHNICAL SPECIFICATIONS

Microphone type: 2 noise-canceling mics with AI-based algorithms and Mic EQ

Frequency response (headset): 20 Hz - 20 kHz (music mode), 100 Hz - 8 kHz (talk mode)

Frequency response (microphone): 100 Hz - 8 kHz

Battery type: Built-in battery (lithium ion)

Battery life (talk time)\*: Up to 20 hrs (ANC on), up to 25 hrs (ANC off)

Battery life (listening time)\*: Up to 25 hrs (ANC on), up to 48 hrs (ANC off)

*Bluetooth*<sup>®</sup> version: 5.3

Wireless range\*: Up to 50 m/170 ft (open field line of sight)

*USB-C* to C charging cable length: 1.5 m

Audio compliance: EN 50332-2 compliant

\* Battery life and wireless range may vary based on environmental and computing conditions.

[www.logitech.com/support/zonewireless2es-b](http://www.logitech.com/support/zonewireless2es-b)

# PRÉSENTATION DU PRODUIT

## VUE AVANT

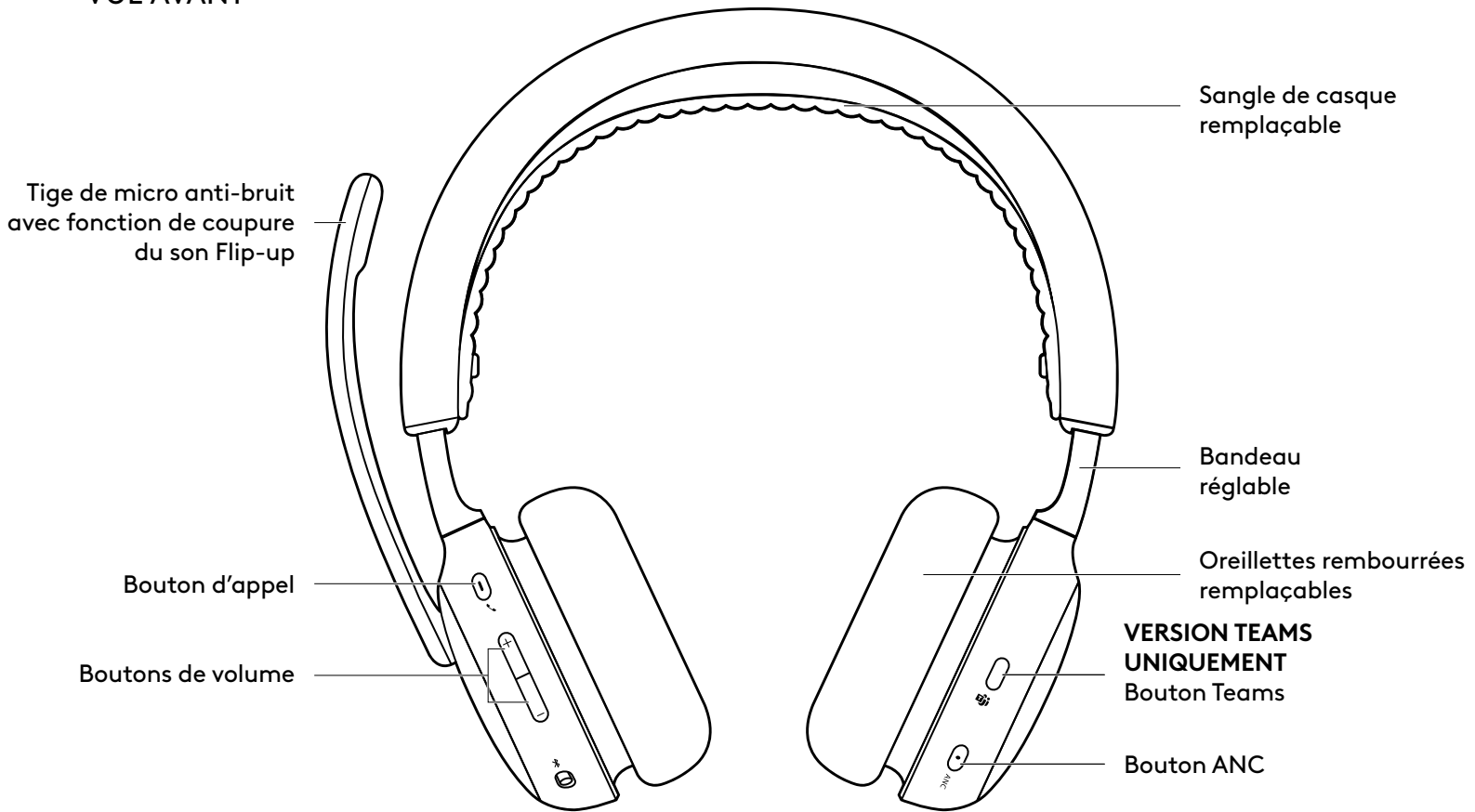

## VUE DE DESSOUS

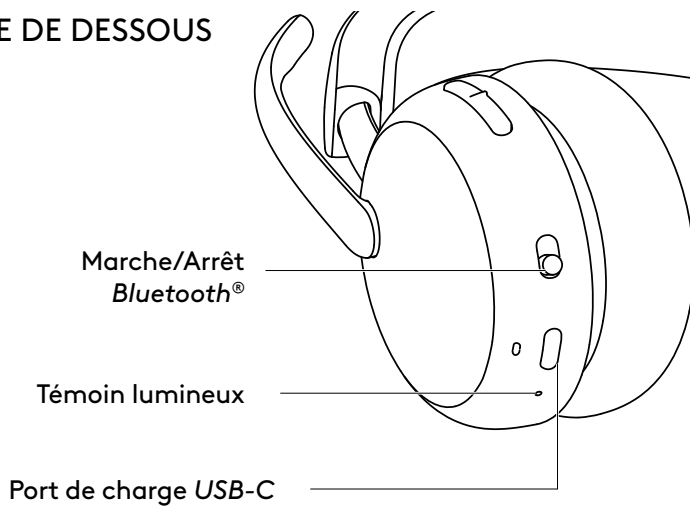

## RÉCEPTEUR USB ET ADAPTATEUR

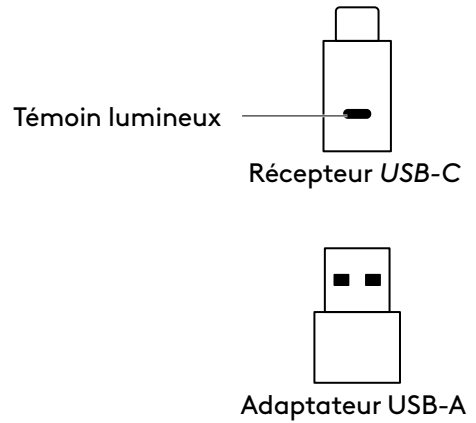

## CONTENU

1. Casque
2. Récepteur *USB-C*
3. Adaptateur *USB-A*
4. Câble de charge *USB-C* vers *USB-C*
5. Pochette de transport
6. Documentation utilisateur

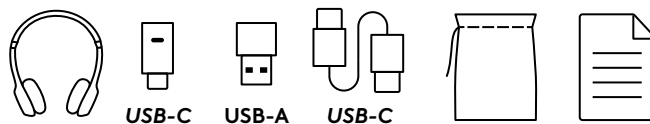

## MARCHE/ARRÊT

1. Faites glisser le commutateur d'alimentation vers le centre.
2. Une fois sous tension, le témoin lumineux devient blanc.
3. Pour mettre hors tension, faites glisser le commutateur d'alimentation sur l'icône d'alimentation.

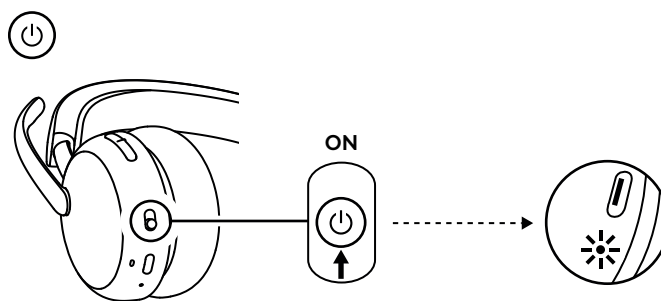

## COUPLAGE VIA UN RÉCEPTEUR USB

### 1. *USB-C*

Insérez le récepteur dans le port *USB-C* de l'ordinateur.

### *USB-A*

Insérez le récepteur *USB-C* dans l'adaptateur *USB-A*. Insérez ensuite l'adaptateur dans le port *USB-A* de l'ordinateur.

2. Le casque est déjà couplé au récepteur avec lequel il est livré. Il vous suffit d'allumer le casque. Une fois le dispositif couplé, le témoin lumineux du récepteur passera au blanc continu. Le témoin lumineux du casque passe au blanc continu.
3. Assurez-vous que « Logi Zone Wireless 2 ES B2B » est sélectionné dans le réglage du son de l'ordinateur.

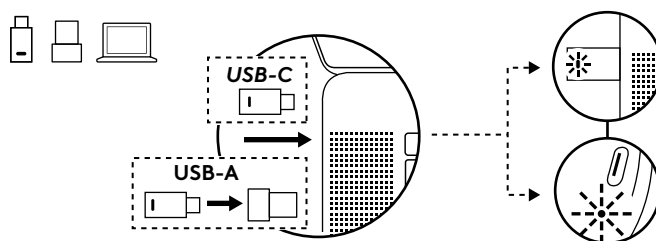

## COUPLAGE VIA BLUETOOTH®

1. Faites glisser le commutateur d'alimentation sur l'icône *Bluetooth*® et maintenez-le pendant 2 secondes. Le témoin lumineux clignote rapidement en blanc.
2. Ouvrez les paramètres *Bluetooth*® sur votre dispositif.
3. Sélectionnez « Logi Zone Wireless 2 ES B2B » dans les dispositifs détectables.
4. Une fois le dispositif couplé, le témoin lumineux passera au blanc continu.

### Conseil (sous Windows 10 uniquement) :

lorsque le casque est couplé à l'ordinateur portable, si nécessaire, accédez au réglage du son et sélectionnez « Logi Zone Wireless 2 ES B2B Stereo » pour écouter de la musique avec une qualité optimale et « Logi Zone Wireless 2 ES B2B Hands-Free » pour les appels

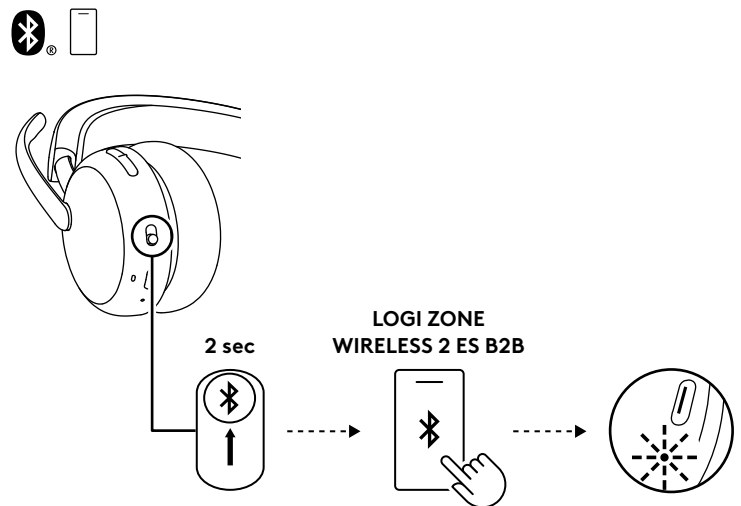

## AJUSTEMENT DU CASQUE

1. Ajustez le casque en faisant glisser les oreillettes vers le haut et le bas du bandeau.
2. Oreillettes pivotantes pour s'adapter à votre oreille.
3. Il sera peut-être plus facile d'ajuster le casque sur votre tête. Déplacez les oreillettes vers le haut ou le bas du bandeau jusqu'à ce que le maintien sur vos oreilles soit confortable.

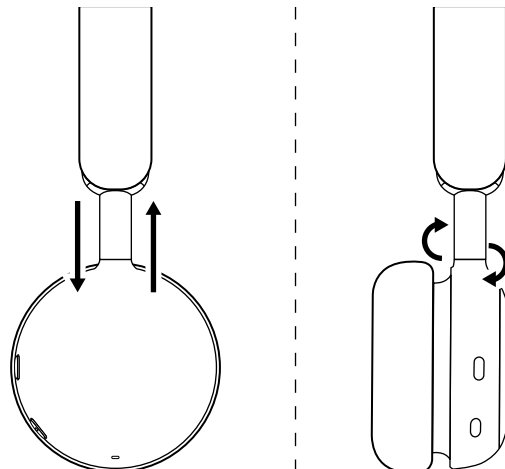

## AJUSTEMENT DE LA TIGE DU MICRO

La tige du micro pivote sur 270 degrés. Portez-la à gauche ou à droite. Le canal audio bascule automatiquement, selon la direction dans laquelle vous portez le micro.

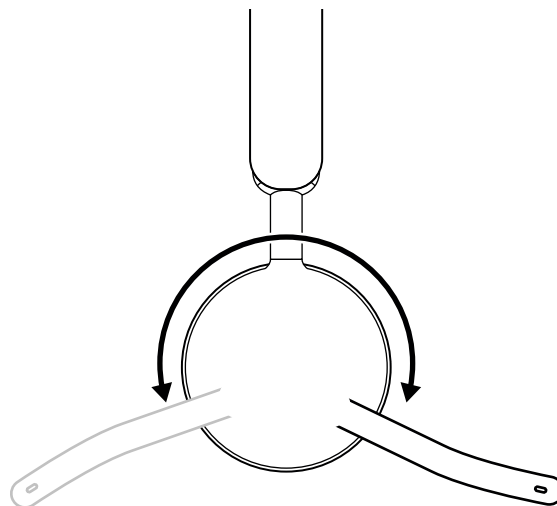

La tige de micro doit être placée à proximité ou à côté de votre bouche, alignée sur le coin de la bouche.



## CHARGEMENT

Le casque s'éteint automatiquement lorsqu'il est inactif.

Le minuteur de mise en veille peut être modifié dans l'application Logi Tune.

Le témoin lumineux du casque passe au ROUGE lorsque la batterie est faible.



### CHARGEMENT VIA UN CÂBLE USB

1. Branchez une extrémité du câble au port *USB-C* situé sous l'oreillette et l'autre extrémité au port de charge *USB-C* de votre ordinateur, de votre dock ou d'un adaptateur secteur.
2. Le témoin lumineux émettra une pulsation blanche pour indiquer le chargement.
3. Le témoin lumineux passera au blanc fixe une fois la batterie entièrement chargée.
  - 2 heures pour charger entièrement la batterie.
  - 5 minutes de charge vous offrent 1 heure de conversation.\*
4. Le casque peut être utilisé avec le récepteur et couplé via *Bluetooth*® pendant le chargement. Il peut également être utilisé comme casque filaire avec le *câble USB-C* connecté lorsque le casque est éteint.

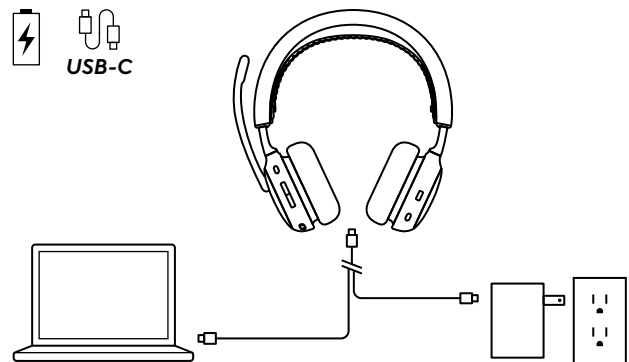
\*L'autonomie dépend de l'environnement et du mode d'utilisation.

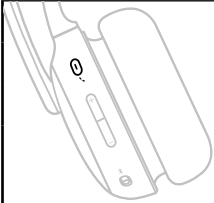
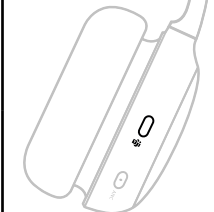
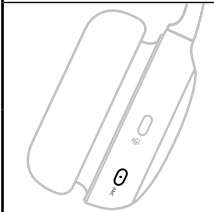

## COMMANDES DU CASQUE

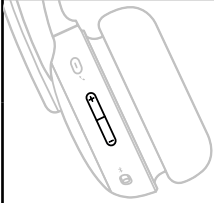
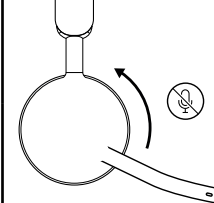
Bouton	Utilisation		Action
	<b>Commande d'appel</b>	Réception/fin d'appel	Pression brève
		Reprendre un appel en attente	
	<b>Assistant vocal</b>	Déclencher l'assistant vocal (en l'absence d'appel)	Appuyez pendant 2 secondes
	<b>Commandes d'appel Teams (version Teams uniquement)</b>	Activités Teams	Pression brève
		Appuyez pendant 2 secondes	
	<b>Contrôles ANC</b>	Basculer entre l'ANC et le mode transparence	Pression brève
		ANC désactivée	Appuyez pendant 2 secondes
	<b>Commandes multimédia (Activer avec Logi Tune)</b>	Lecture/Pause	Pression brève
		Piste suivante	Double pression
		Piste précédente	Triple pression
	<b>Commandes de volume</b>	Monter le volume	Brève pression vers le haut
		Baisser le volume	Brève pression vers le bas
	<b>Couper le son</b>	Son coupé	Relever la tige du micro
		Son réactivé	Abaisser la tige de micro

### Remarque :

- Les activités de Teams ne sont fonctionnelles que lorsque Teams s'exécute sur un ordinateur déverrouillé.
- La fonctionnalité des commandes média dépend des types d'applications. Elle ne peut être configurée que via l'application Logi Tune.
- Les activités d'appel sont toujours prioritaires par rapport à la diffusion multimédia en direct. Lorsque deux dispositifs sont connectés, la connexion *Bluetooth*® a la priorité par rapport au récepteur. Lorsque deux dispositifs *Bluetooth*® sont connectés, le dernier dispositif actif est prioritaire sur l'autre. De plus, la priorité entre deux dispositifs *Bluetooth*® peut être personnalisée dans l'application Logi Tune sous Dispositifs connectés.
- Pour en savoir plus sur le bouton Teams, consultez la page de support *Microsoft* : Utilisez le bouton *Microsoft Teams* sur votre dispositif Teams certifié.
- Des invitations vocales indiquent lorsque le micro est activé/désactivé.

**Astuce :** L'ANC peut être personnalisée dans l'application Logi Tune.

## SUPPRESSION DE L'ÉCHO (ANC)

L'ANC bloque le bruit autour de vous pour vous aider à vous concentrer sur la tâche à accomplir.

- Appuyez sur le bouton ANC sur le côté de l'oreillette pour basculer entre les modes ANC et transparence.
- Des invites vocales sont diffusées lorsque vous passez d'un mode à l'autre.

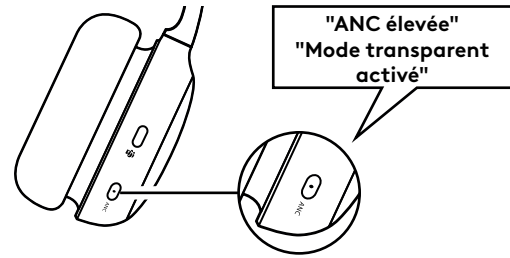

**Remarque :** le bouton ANC peut être personnalisé pour faire défiler jusqu'à 5 modes différents dans l'application Logi Tune.

## TÉMOIN LUMINEUX DU CASQUE

Légère		État
Blanc	Lumière continue	Mise sous tension
		Connecté à un dispositif
		Batterie entièrement chargée
	Clignotement	Charge de la batterie
Rouge	Clignotant	Appel entrant
		Mode de couplage <i>Bluetooth</i> ®
Rouge	Témoin clignotant	Batterie faible
	Lumière continue	Sourdine activée
Violet et blanc	Témoin clignotant	Mise à jour du micrologiciel du casque

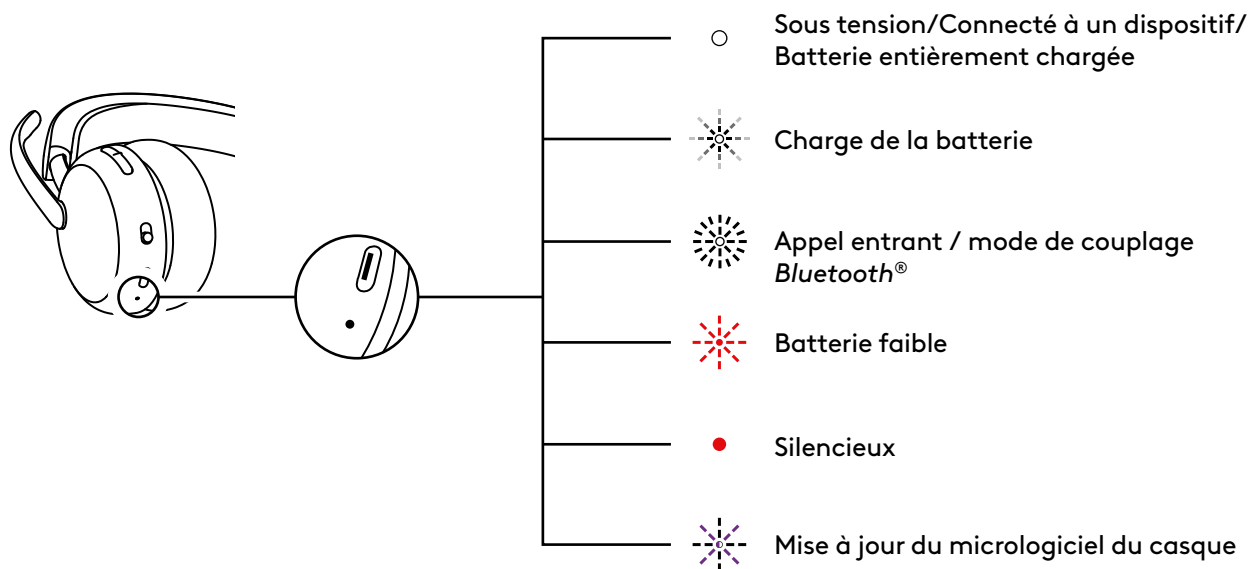

## TÉMOIN DU RÉCEPTEUR

Version Microsoft Teams		
	Légère	État
<b>Blanc</b>	Lumière continue	Connecté
	Témoin clignotant de façon alternative	Appel entrant
<b>Violet</b>	Lumière continue	Connecté à Teams
	Clignotement	Connexion à Teams / Notifications Teams
	Trois clignotements	Non connecté à Teams
	Clignotement pendant 10 secondes	Échec de la connexion à Teams
<b>Rouge</b>	Lumière continue	Sourdine activée
<b>Bleu</b>	Clignotant	Couplage

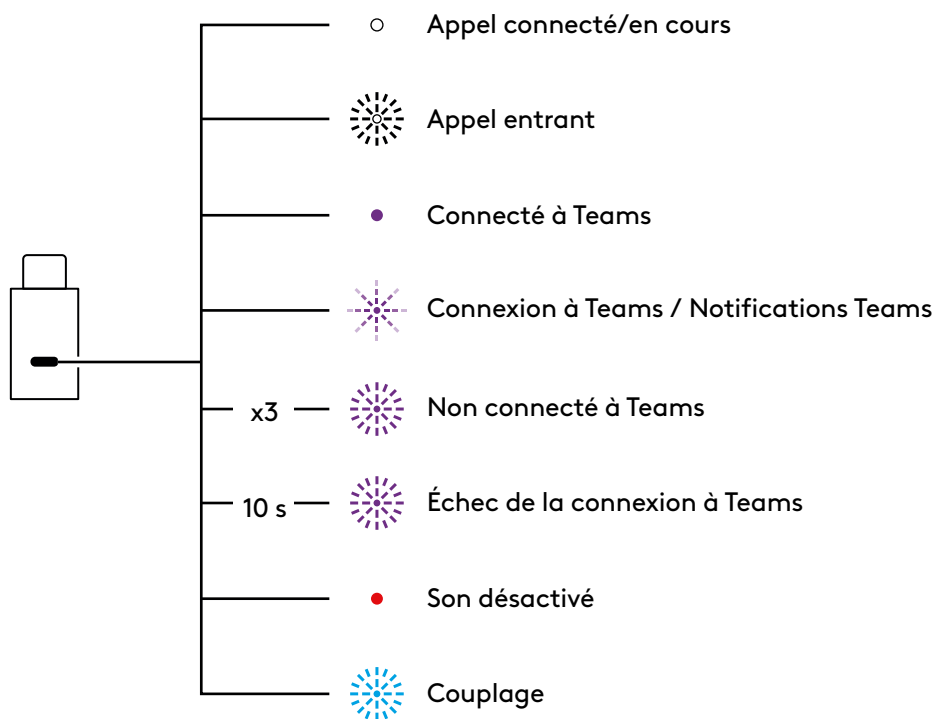

Version UC		
Légère		État
Blanc	Lumière continue	Connecté
	Témoin clignotant de façon alternative	Appel en cours
Rouge	Lumière continue	Appel entrant
Bleu	Lumière continue	Sourdine activée
	Clignotant	Couplage

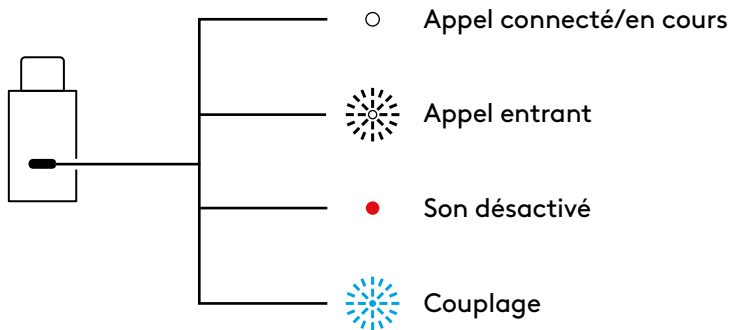

### AUDIO PAR USB (COMPATIBLE HAUTE DENSITÉ)

Si votre son est instable pendant un appel en raison d'un trop grand nombre de dispositifs sans fil à proximité (densité élevée), vous pouvez utiliser le casque comme un casque filaire.

1. Mettez le casque hors tension
2. Connectez le casque au câble USB fourni. Branchez ensuite l'autre extrémité du *câble USB-C* dans le *port USB-C* de votre ordinateur.
3. Assurez-vous que « Logi Zone Wireless 2 ES B2B-USB » est sélectionné dans les paramètres du dispositif audio.

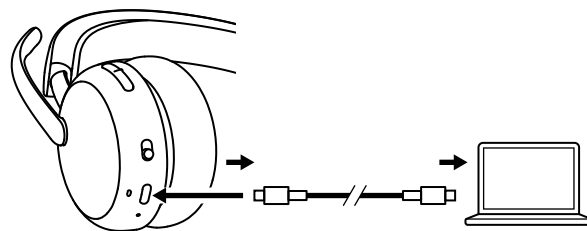

**Remarque :** le casque se chargerait dans ce mode. Les boutons de commande peuvent ne pas être disponibles dans ce mode.

## LOGI TUNE

Logi Tune vous aide à booster les performances de votre casque avec des mises à jour régulières du logiciel et du micrologiciel. Pour en savoir plus, téléchargez Logi Tune à l'adresse [logitech.com/tune](https://logitech.com/tune), dans l'*Apple App Store* ou *Google Play*.



## RÉGLAGE DE LA TONALITÉ

La tonalité vous permet d'entendre votre propre voix lors des conversations pour que vous sachiez si vous parlez trop fort. Dans l'application Logi Tune, sélectionnez la fonctionnalité Tonalité, puis réglez la molette en conséquence.

- Une valeur plus élevée signifie que vous entendrez plus de sons externes.
- Une valeur plus faible signifie que vous entendrez moins de sons externes.

## MINUTEUR DE MISE EN VEILLE AUTOMATIQUE

Par défaut, votre casque s'éteint automatiquement s'il n'est pas utilisé pendant 30 minutes. Ajustez le minuteur de mise en veille dans l'application Logi Tune.

## ÉGALISEUR DE MICRO

Personnalisez l'égaliseur de micro dans Logi Tune pour ajuster votre voix afin qu'elle soit plus aiguë ou plus grave.

## PROTECTION AUDITIVE

Zone Wireless 2 ES for Business offre trois types de protection pour vous aider à entendre en toute sécurité.

**Limitation de crête :** Le volume audio est toujours limité à 100 dBA pour éviter les dommages auditifs.

**Protection contre les chocs acoustiques :** Cette protection élimine les pics audio soudains pour éviter les chocs acoustiques conformément à la directive australienne G616. Cette fonctionnalité peut être activée dans l'application Logi Tune et s'applique uniquement aux activités d'appel.

**Exposition au bruit dans le temps :** Cette protection protège vos oreilles de l'exposition au bruit sur une période de 8 heures avec une limite maximale de 85 dBA conformément à la directive australienne G616. Cette fonctionnalité peut être activée dans l'application Logi Tune et s'applique uniquement aux activités d'appel.

## MISE À JOUR DE VOTRE CASQUE

Il est recommandé de mettre à jour votre casque et votre récepteur. Pour ce faire, téléchargez Logi Tune depuis [logitech.com/tune](https://logitech.com/tune) et recherchez les mises à jour du micrologiciel disponibles.

**Remarque :** éteignez le casque, puis rallumez-le une fois la mise à jour terminée pour vous assurer qu'elle a été effectuée avec succès.

## VEUILLEZ RECONNECTER VOTRE CASQUE

Si le casque est déconnecté du récepteur, vous pouvez le reconnecter via Logi Tune.

1. Branchez le récepteur *USB-C* ou l'adaptateur *USB-A* avec le récepteur *USB-C* sur le port *USB* de l'ordinateur.
2. Mettez le casque sous tension en faisant glisser le commutateur d'alimentation vers le centre.
3. Ouvrez Logi Tune Desktop sur votre ordinateur.
4. Sélectionnez « Zone Receiver » dans le tableau de bord.
5. Patientez pendant que l'application recherche le dernier casque connecté.
6. Si aucun casque n'est connecté au récepteur, cliquez sur « Coupler le casque ».
7. Passez en mode couplage sur le casque en faisant glisser le commutateur d'alimentation sur l'icône *Bluetooth*® et en le maintenant pendant 2 secondes. Le témoin lumineux clignote rapidement en blanc.
8. Une fois le couplage réussi, le témoin lumineux du récepteur et du casque passe au blanc continu.

## RÉINITIALISATION DE VOTRE CASQUE

Pour réinitialiser votre casque à son état d'origine, allumez-le, appuyez longuement sur le bouton d'augmentation du volume et faites glisser le bouton d'alimentation en mode couplage pendant 5 secondes. Le casque est réinitialisé avec succès lorsque le témoin lumineux du casque clignote rapidement en rouge et blanc 3 fois, puis s'éteint.

## DIMENSIONS

### Casque :

Hauteur x largeur x profondeur :  
185,2 x 183,6 x 73,0 mm

### Poids :

212 g

### Récepteur :

Hauteur x Largeur x Épaisseur :  
26,8 x 12,4 x 6,2 mm

### Adaptateur :

Hauteur x Largeur x Épaisseur :  
24,5 x 15,4 x 8,7 mm

## CONFIGURATION REQUISE

Compatible avec la plupart des applications d'appels vidéo sur la majorité des plates-formes et systèmes d'exploitation. Compatible avec les ordinateurs *Windows*, *Mac* ou *Chrome* via *USB-C*, *USB-A*, *Bluetooth®* et les dispositifs compatibles *iOS* ou *Android Bluetooth®*.

## CARACTÉRISTIQUES TECHNIQUES

Type de microphone : 2 micros anti-parasite avec algorithmes basés sur l'IA et égaliseur micro

Réponse en fréquence (casque) : 20 Hz - 20 kHz (mode Musique), 100 Hz - 8 kHz (mode Conversation)

Réponse en fréquence (microphone) : 100 Hz - 8 kHz

Type de piles : Batterie intégrée (lithium-ion)

Autonomie de la batterie (autonomie en conversation)\* : jusqu'à 20 heures (ANC activé), jusqu'à 25 heures (ANC désactivé)

Longévité de la batterie (autonomie en écoute)\* : jusqu'à 25 heures (ANC activé), jusqu'à 48 heures (ANC désactivé)

Version *Bluetooth®* : 5,3

Portée sans fil\* : jusqu'à 50 m/170 pieds (champ de vision dégagé)

Longueur du câble (câble de charge *USB-C* vers C : 1,5 m

Conformité audio : Conforme à la norme EN 50332-2

\*La longévité des piles et la portée sans fil sont susceptibles de varier en fonction de l'environnement et du mode d'utilisation.

[www.logitech.com/support/zonewireless2es-b](http://www.logitech.com/support/zonewireless2es-b)

## COMPONENTES DEL PRODUCTO

### VISTA FRONTAL

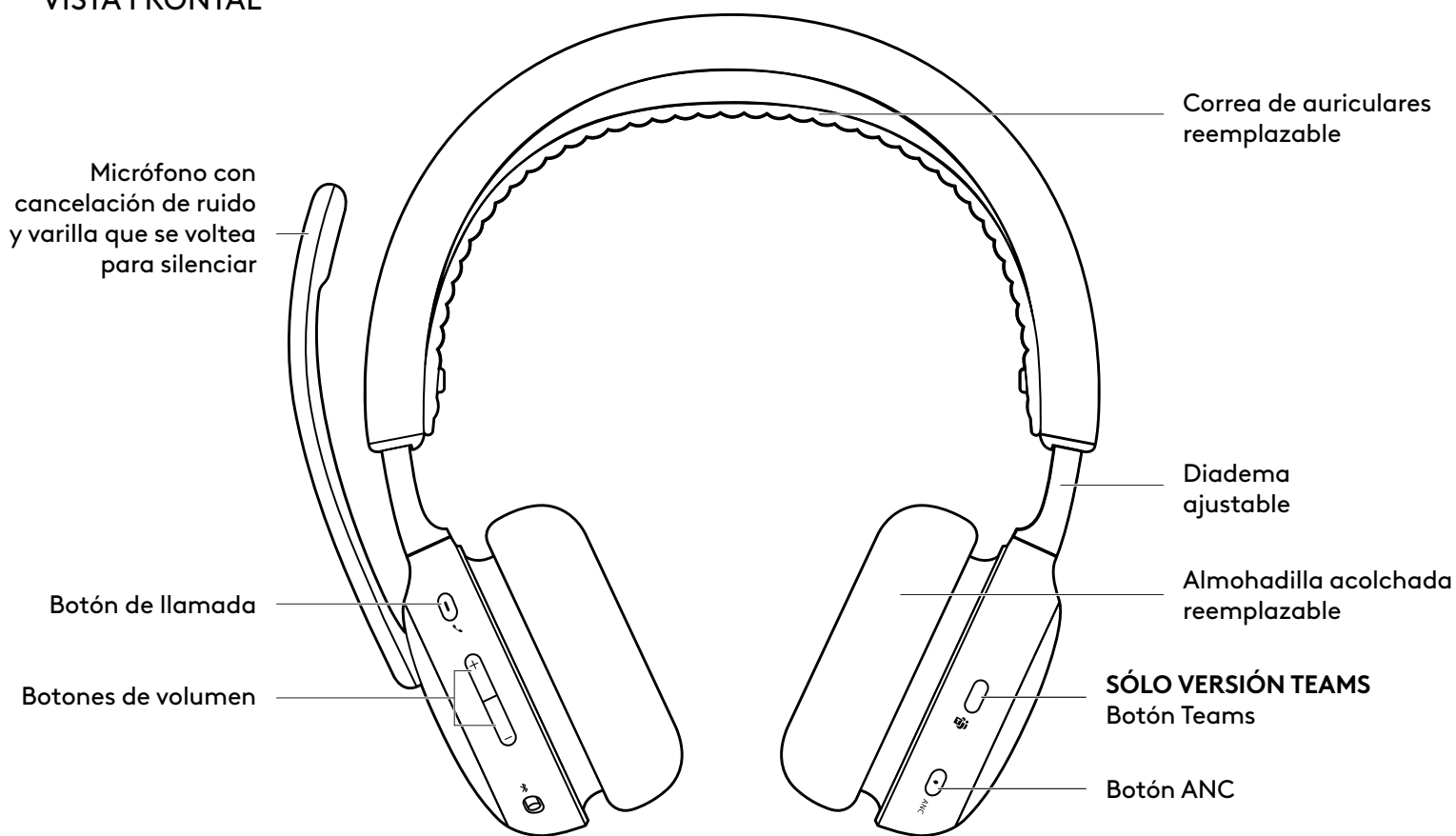

### VISTA INFERIOR

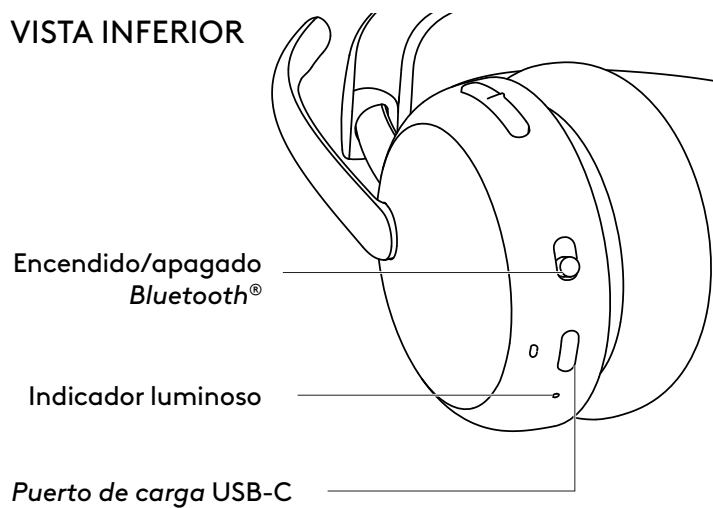

### RECEPTOR USB Y ADAPTADOR

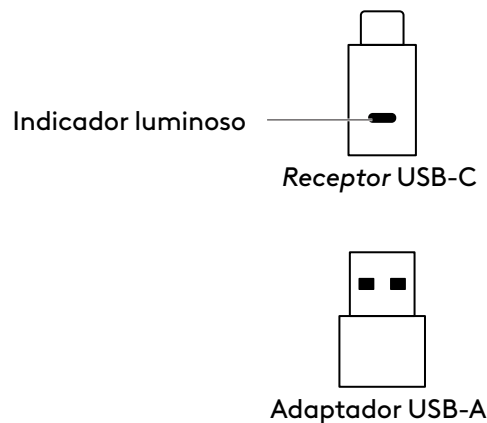

## CONTENIDO DE LA CAJA

1. Audífonos
2. Receptor *USB-C*
3. Adaptador *USB-A*
4. Cable de carga *USB-C* a *C*
5. Bolsa de viaje
6. Documentación para el usuario

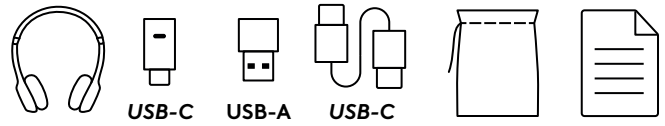

## ENCENDIDO/APAGADO

1. Desliza el interruptor de encendido hacia el centro.
2. Cuando están encendidos el indicador luminoso muestra luz blanca.
3. Para apagarlos, desliza el interruptor de encendido hacia el ícono de encendido.

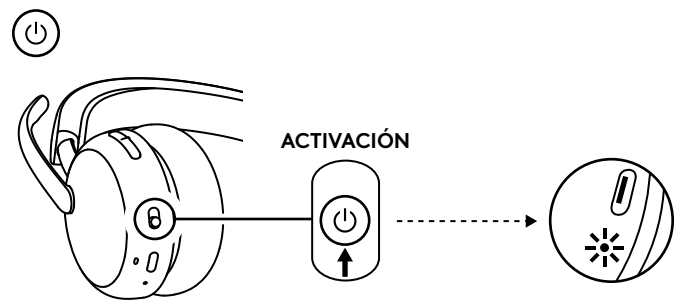

## EMPAREJAR MEDIANTE RECEPTOR USB

1. **USB-C**  
Inserta el receptor en el puerto *USB-C* de la computadora.
- USB-A**  
Inserta el receptor *USB-C* en el adaptador *USB-A*. Luego inserta el adaptador en el puerto *USB-A* de la computadora.
2. Los auriculares ya vienen emparejados de fábrica con el receptor incluido en el paquete. Sólo hay que encender los audífonos. Cuando se complete el emparejamiento, el indicador luminoso del receptor permanecerá iluminado en blanco. El indicador luminoso de los auriculares permanecerá encendido en blanco.
3. "Logi Zone Wireless 2 ES B2B" debe estar seleccionado en la configuración de sonido de la computadora.

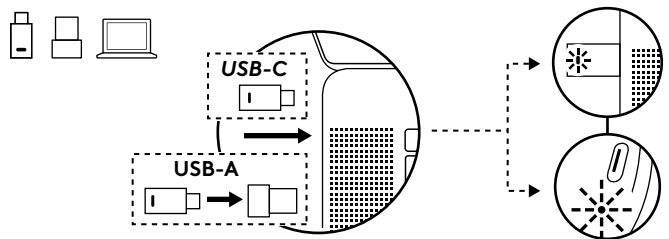

## EMPAREJAMIENTO MEDIANTE BLUETOOTH®

1. Desliza el interruptor de encendido hacia el ícono de *Bluetooth*® y mantenlo presionado durante 2 segundos. El indicador luminoso parpadeará en blanco rápidamente.
2. Abre la configuración de *Bluetooth*® en el dispositivo.
3. Selecciona "Logi Zone Wireless 2 ES B2B" en dispositivos detectables.
4. Cuando se complete el emparejamiento, el indicador luminoso permanecerá encendido n blanco.

### Sugerencia (sólo para *Windows 10*):

Cuando los auriculares estén emparejados a una laptop, si es necesario, ve a la configuración de sonido y selecciona "Logi Zone Wireless 2 ES B2B Stereo" para obtener la mejor calidad de música y selecciona "Logi Zone Wireless 2 ES B2B Hands-Free" para llamadas.

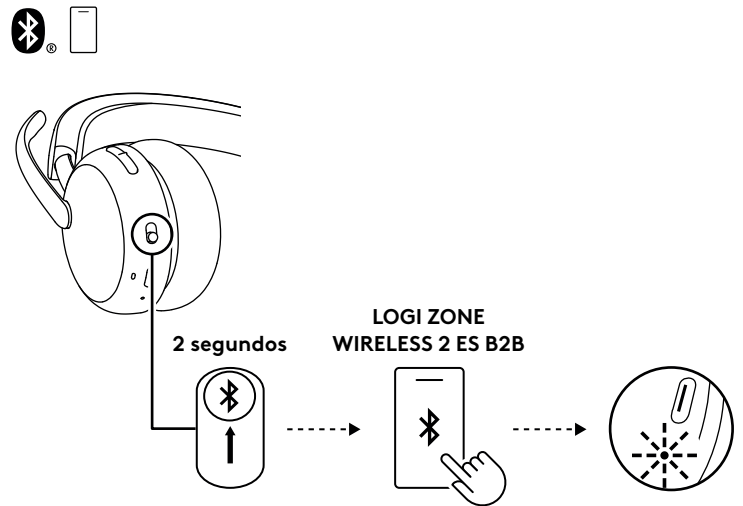

## AJUSTAR LOS AUDÍFONOS

1. Ajusta los auriculares deslizando las copas hacia arriba o hacia abajo en la diadema.
2. Gira las copas para acomodarlas a las orejas.
3. Esta operación puede resultar más fácil si tienes los audífonos puestos. Mueve las copas hacia arriba y hacia abajo en la diadema hasta que las notes cómodamente asentadas sobre las orejas.

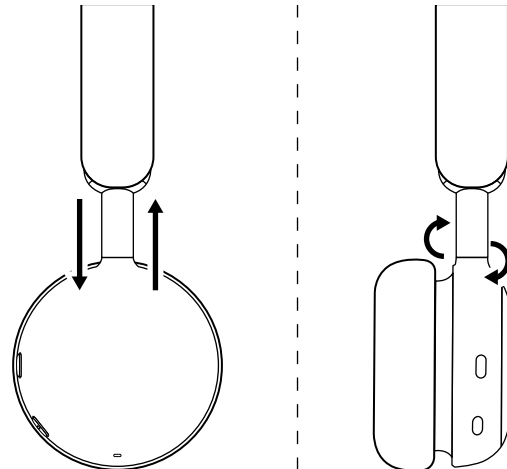

## AJUSTAR LA VARILLA DEL MICRÓFONO

La varilla del micrófono gira 270 grados. Se puede colocar en el lado derecho o el izquierdo. El canal de audio cambiará automáticamente, dependiendo de la orientación del micrófono.

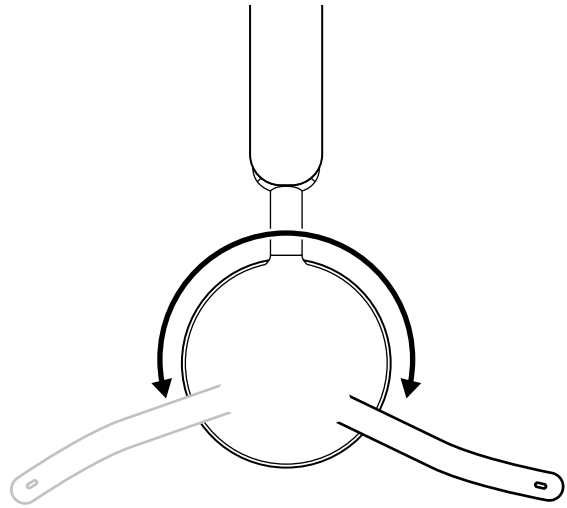

La varilla del micrófono debe colocarse cerca o al lado de la boca, alineada con la comisura de la boca.

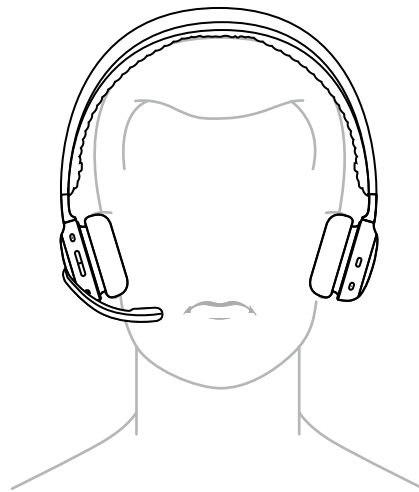

## CARGA

Los auriculares se apagan automáticamente cuando están inactivos.

El ajuste del temporizador de suspensión se puede cambiar en la aplicación Logi Tune.

El indicador luminoso de los auriculares se iluminará en ROJO cuando el nivel de carga sea bajo.

### CARGAR MEDIANTE EL CABLE USB

1. Conecta un extremo del cable al puerto *USB-C* en la parte inferior de la copa y el otro extremo al puerto de carga *USB-C* de la computadora, la base o a un adaptador de alimentación.
2. El indicador luminoso realizará un efecto de respiración con luz blanca durante la carga.
3. La luz será blanca permanente cuando los audífonos estén totalmente cargados.
  - La carga completa tarda dos horas.
  - Cinco minutos de carga proporcionan una hora de tiempo de conversación.\*
4. Durante la carga, los auriculares se pueden usar con el receptor y emparejados mediante *Bluetooth*®. También se pueden usar como audífonos con cable con el cable *USB-C* conectado mientras los audífonos están apagados.

\*La duración de la batería depende de las condiciones del entorno y de los dispositivos.

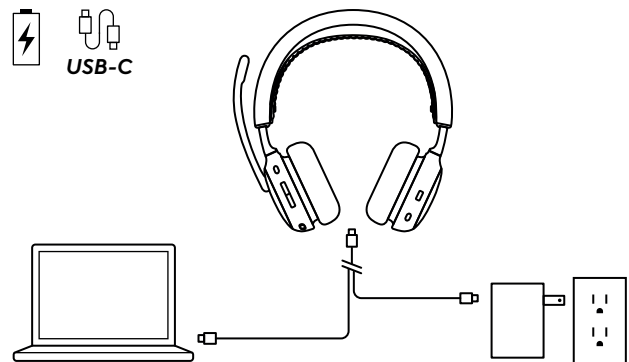

## CONTROLES DE LOS AUDÍFONOS

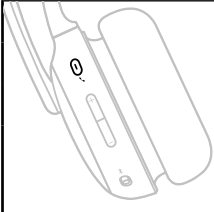
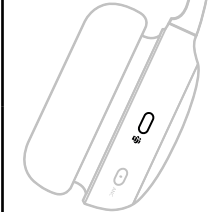
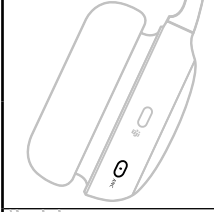
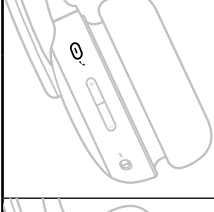
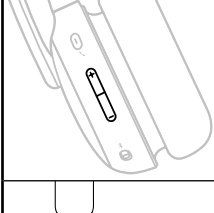
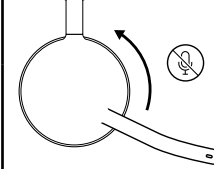
Botón	Uso		Acción
	<b>Controles de llamadas</b>	Responder/Finalizar llamada	Pulsación corta
		Reanudar llamada en espera	
	<b>Asistencia de voz</b>	Activar asistente de voz (cuando no hay actividad de llamadas)	Pulsación de 2 segundos
	<b>Controles de llamadas de Teams (sólo para versión Teams)</b>	Actividades de Teams	Pulsación corta
			Pulsación de 2 segundos
	<b>Controles ANC</b>	Alternar entre ANC y transparencia	Pulsación corta
		ANC desactivada	Pulsación de 2 segundos
	<b>Controles multimedia (habilitar con Logi Tune)</b>	Reproducir/Pausar	Pulsación corta
		Pista siguiente	Doble pulsación
		Pista anterior	Pulsación triple
	<b>Controles de volumen</b>	Subir volumen	Pulsación corta
		Bajar volumen	Pulsación corta hacia abajo
	<b>Silencio</b>	Silencio activado	Varilla de micrófono hacia arriba
		Silencio desactivado	Varilla de micrófono hacia abajo

### Nota:

- Las actividades de Teams sólo funcionan cuando Teams se ejecuta en una computadora desbloqueada.
- Las funciones de control multimedia dependen del tipo de aplicación. Solo se puede configurar a través de la aplicación Logi Tune.
- Las actividades de llamadas siempre tienen prioridad sobre el streaming multimedia. Cuando haya dos dispositivos conectados, el conectado por *Bluetooth*® tendrá prioridad sobre el receptor. Cuando se conecten dos dispositivos *Bluetooth*®, el que estuvo activo más recientemente tendrá prioridad. La prioridad entre dos dispositivos *Bluetooth*® se puede personalizar en la aplicación Logi Tune, en Dispositivos conectados.
- Para obtener más información sobre el botón de Teams, visita la página de asistencia de *Microsoft* : Usa el botón de *Microsoft Teams* en tu dispositivo Teams certificado.
- Los mensajes de voz indican cuando el micrófono está silenciado.

**Consejo:** La ANC se puede personalizar en la aplicación Logi Tune.

## CANCELACIÓN ACTIVA DE RUIDO (ANC)

La función de cancelación bloquea el ruido del entorno para mejorar la concentración del usuario.

- Presiona el botón ANC en el lateral de la copa del auricular para alternar entre los modos ANC y Transparencia.
- Habrá mensajes de voz al cambiar de modo.

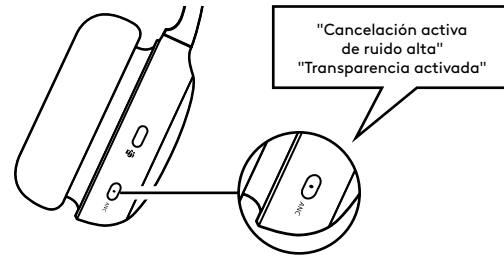

**Nota:** El botón ANC se puede personalizar para recorrer hasta 5 modos en la aplicación Logi Tune.

## INDICADOR LUMINOSO DE LOS AUDÍFONOS

Luz		Estado
<b>Blanco</b>	Permanente	Encendido
		Conexión a un dispositivo
		Batería completamente cargada
	Pulsante	Carga en curso
	Parpadeante	Llamada entrante
Modo de emparejamiento <i>Bluetooth</i> ®		
<b>Rojo</b>	Parpadeante	Carga de batería baja
	Permanente	Silencio activado
<b>Púrpura y blanco</b>	Parpadeante	Actualización de firmware de los audífonos

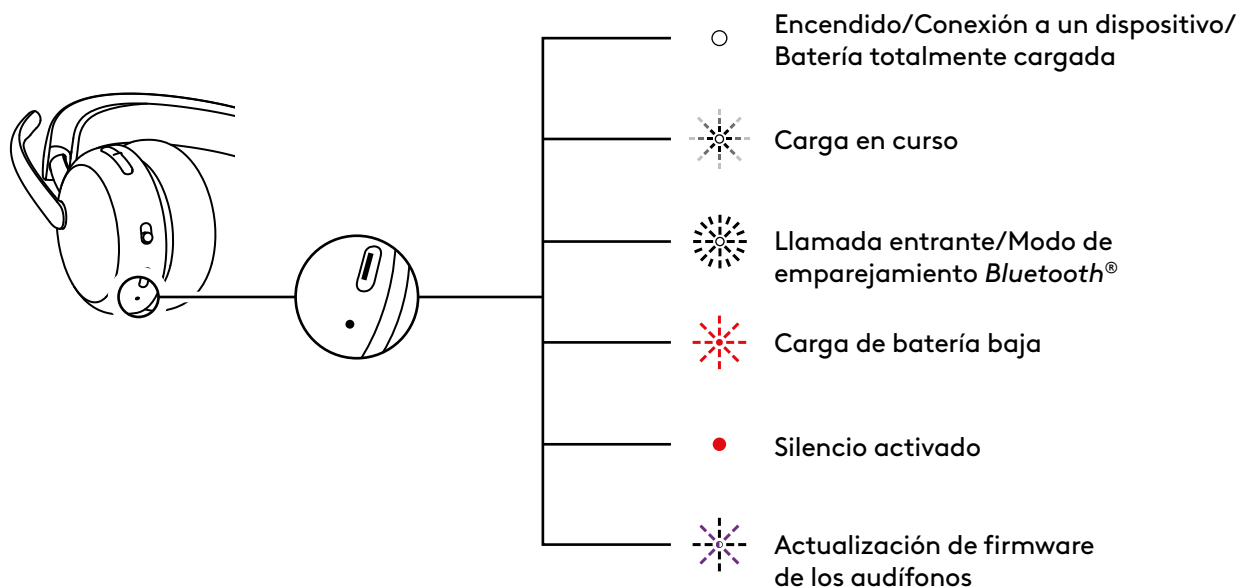

## INDICADOR LUMINOSO DEL RECEPTOR

Versión de Microsoft Teams		
	Luz	Estado
<b>Blanco</b>	Permanente	Conectado
		Llamada en curso
	Repetición de destellos activada y desactivada	Llamada entrante
<b>Morado</b>	Permanente	Conexión a Teams
	Pulsante	Conectando a Teams/ notificaciones de Teams
	Destellos tres veces y desactivados	No hay conexión a Teams
	Destellos durante 10 segundos y desactivados	No se pudo conectar a Teams
<b>Rojo</b>	Permanente	Silencio activado
<b>Azul</b>	Destellos	Emparejamiento

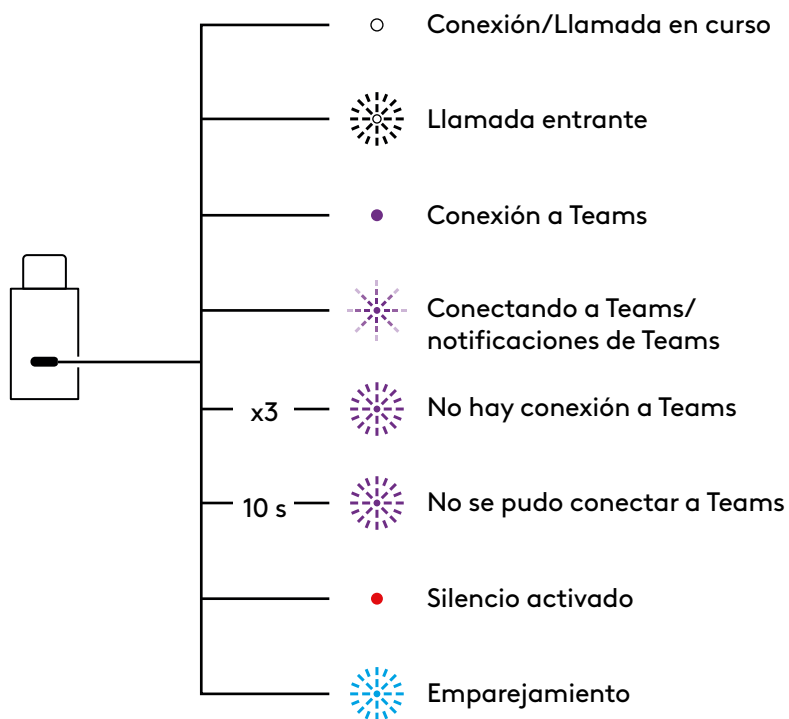

Versión UC		
Luz		Estado
Blanco	Permanente	Conectado
	Repetición de destellos activada y desactivada	Llamada entrante
Rojo	Permanente	Silencio activado
Azul	Destellos	Emparejamiento



### AUDIO POR USB (ADECUADO PARA ALTA DENSIDAD)

Si el audio es inestable durante una llamada porque hay demasiados dispositivos inalámbricos cerca (alta densidad), los audífonos se pueden usar con cable.

1. Apaga los audífonos.
2. Conecta los audífonos al cable USB suministrado. Conecta el otro extremo del cable *USB -C* al puerto *USB-C* de la computadora.
3. Asegúrate de que "Logi Zone Wireless 2 ES B2B-USB" esté seleccionado en la configuración del dispositivo de audio.

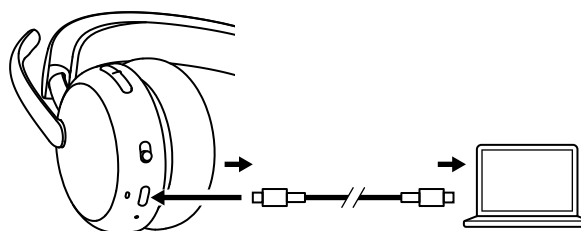

**Nota:** los audífonos se cargarán en este modo. Es posible que los controles de botones no estén disponibles en este modo.

## LOGI TUNE

Logi Tune optimiza el desempeño de los audífonos con actualizaciones periódicas de software y firmware. Conoce más y descarga Logi Tune desde [logitech.com/tune](https://logitech.com/tune), la *Apple App Store* o la tienda *Google Play*.



## AJUSTAR EL TONO LATERAL

El tono lateral permite oír la propia voz durante las conversaciones, para comprobar el volumen de voz utilizado. En la aplicación Logi Tune, selecciona la función de tono lateral y ajusta el control giratorio.

- Un número alto significa que se escuchará más sonido externo.
- Un número bajo significa que se escuchará menos sonido externo.

## TEMPORIZADOR DE SUSPENSIÓN AUTOMÁTICA

De forma predeterminada, los auriculares se apagarán automáticamente cuando lleven 30 minutos sin usarse. Ajusta el temporizador de suspensión en la aplicación Logi Tune.

## ECUALIZADOR DE MICRÓFONO

Personaliza el ecualizador de micrófono en Logi Tune para ajustar tu voz para que suene más alegre o más profunda.

## PROTECCIÓN AUDITIVA

Zone Wireless 2 ES for Business proporciona tres tipos de protección para ayudarte a oír sin riesgos para tu salud.

**Limitación de pico:** El volumen de audio siempre está limitado a 100 dBA para evitar el daño auditivo.

**Protección contra sobresaltos:** Elimina los picos de audio repentinos para evitar golpes acústicos, conforme a la directriz australiana G616. Esto se puede activar en la aplicación Logi Tune y sólo se aplica a actividades de llamadas.

**Exposición prolongada al ruido:** Protege tus oídos de la exposición al ruido por un periodo de 8 horas con un límite de hasta 85 dBA conforme a la directriz australiana G616. Esto se puede activar en la aplicación Logi Tune y sólo se aplica a actividades de llamadas.

## ACTUALIZAR LOS AUDÍFONOS

Es aconsejable actualizar tanto los audífonos como el receptor. Para hacerlo, descarga Logi Tune desde [logitech.com/tune](https://logitech.com/tune) y comprueba si hay actualizaciones de firmware disponibles.

**Nota:** Apaga y enciende los auriculares después de terminar la actualización, para asegurarte de que se haya realizado correctamente.

## VOLVER A CONECTAR LOS AUDÍFONOS

En caso de que los audífonos se desconecten del receptor, puedes volver a conectarlos a través de Logi Tune.

1. Conecta el receptor *USB-C* o el adaptador *USB-A* con el receptor *USB-C* al puerto *USB* de la computadora.
2. Enciende los audífonos deslizando el interruptor de encendido hacia el centro.
3. Abre Logi Tune para escritorio en tu computadora.
4. Selecciona "Zone Receiver" en el panel.
5. Espera mientras se realiza la búsqueda de los audífonos conectados previamente.
6. Si no se ven auriculares conectados al receptor, haz clic en "Emparejar auriculares".
7. Para activar el modo de emparejamiento en los auriculares, desliza el interruptor de encendido hacia el ícono de *Bluetooth*® y mantenlo presionado durante 2 segundos. El indicador luminoso parpadeará en blanco rápidamente.
8. Una vez completado el emparejamiento, el indicador luminoso del receptor y de los auriculares mostrará una luz blanca fija.

## RESTABLECER LOS AUDÍFONOS

Para restablecer los auriculares a su estado original, enciéndelos, mantén presionado el botón de subir volumen y desliza el botón de encendido al modo de emparejamiento durante 5 segundos. Los audífonos estarán correctamente restablecidos cuando el indicador luminoso de los audífonos emita tres destellos rápidos rojos y blancos, y luego se apague.

## DIMENSIONES

### Audífonos:

Altura x Ancho x Profundidad:  
185,2 x 183,6 x 73,0 mm

### Peso:

212 g

### Receptor:

Altura x ancho x profundidad:  
26,8 x 12,4 x 6,2 mm

### Adaptador:

Altura x Ancho x Profundidad:  
24,5 x 15,4 x 8,7 mm

## REQUISITOS DEL SISTEMA

Funcionan con las principales aplicaciones de llamadas en casi todas las plataformas y sistemas operativos. Funcionan con computadoras *Windows*, *Mac* o *Chrome* mediante *USB-C*, *USB-A*, *Bluetooth®* y *iOS* o dispositivos *Android* con *Bluetooth®*.

## ESPECIFICACIONES TÉCNICAS

Tipo de micrófono: 2 micrófonos con cancelación de ruido con algoritmos basados en IA y ecualizador de micrófono

Respuesta de frecuencia (audífonos con micrófono): 20 Hz - 20 kHz (modo música), 100 Hz - 8 kHz (modo conversación)

Respuesta de frecuencia (micrófono): 100 Hz - 8 kHz

Tipo de batería: Batería integrada (ion litio)

Duración de la batería (tiempo de conversación)\* Hasta 20 h (ANC activada), hasta 25 h (ANC desactivada)

Duración de la batería (tiempo de escucha)\*: Hasta 25 h (ANC activada), hasta 48 h (ANC desactivada)

Versión de *Bluetooth®*: 5.3

Radio de acción inalámbrico\* Hasta 50 m (170 ft) (línea de visión en campo abierto)

Longitud del cable de carga *USB-C* a *C*: 1.5 m

Cumplimiento de las normativas de audio: Cumple con la normativa EN 50332-2

\*La duración de la batería y el radio de acción inalámbrico dependen de las condiciones del entorno y de los dispositivos.

[www.logitech.com/support/zonewireless2es-b](http://www.logitech.com/support/zonewireless2es-b)

## CONHECER O PRODUTO

### VISTA FRONTAL



### VISTA INFERIOR

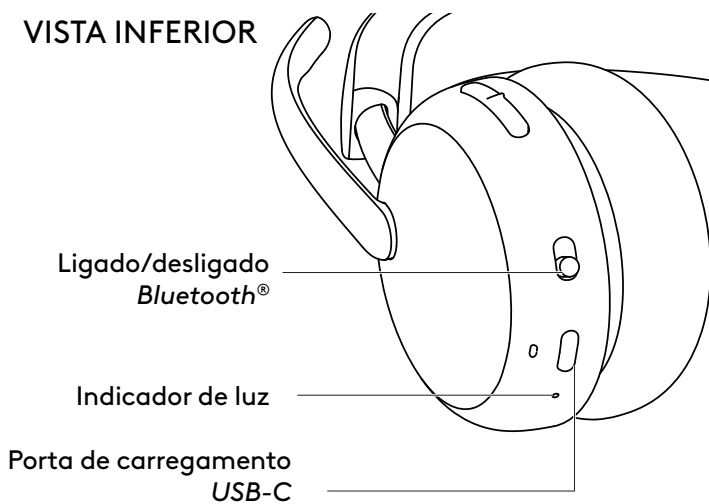

### RECEPTOR USB E ADAPTADOR

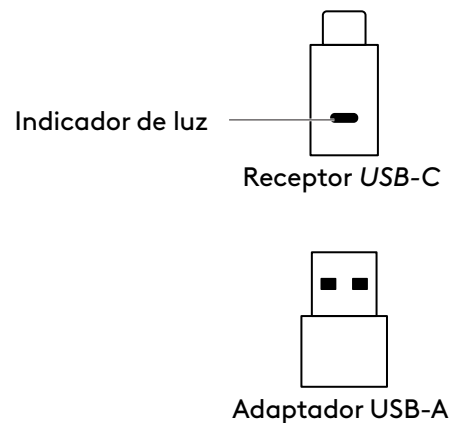

## CONTEÚDO DA EMBALAGEM

1. Headset
2. Receptor *USB-C*
3. Adaptador *USB-A*
4. Cabo de carregamento *USB-C* para *C*
5. Bolsa para transporte
6. Documentação para o usuário

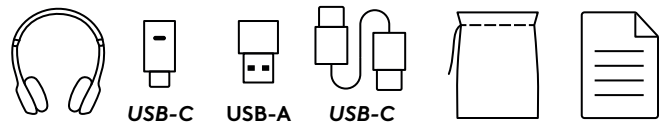

## LIGAR/DESLIGAR

1. Deslize o botão liga/desliga para o centro.
2. Quando ligado, o indicador luminoso fica branco.
3. Para desligar, deslize o botão liga/desliga até o ícone de energia.

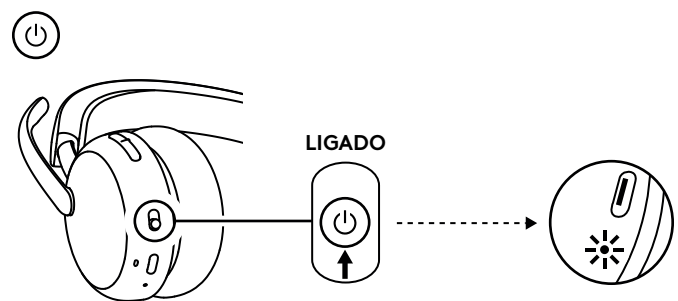

## PAREAMENTO VIA RECEPTOR USB

1. **USB-C**  
Insira o receptor na porta *USB-C* do computador.

### USB-A

Insira o receptor *USB-C* no adaptador *USB-A*. Em seguida, insira o adaptador na porta *USB-A* do computador.

2. O headset já está pareado com o receptor fornecido. Basta ligar o headset. Uma vez emparelhado com sucesso, o indicador luminoso no receptor permanecerá branco sólido. O indicador de luz no headset ficará branco.
3. Certifique-se de que "Logi Zone Wireless 2 ES B2B" esteja selecionado na configuração de som do computador.

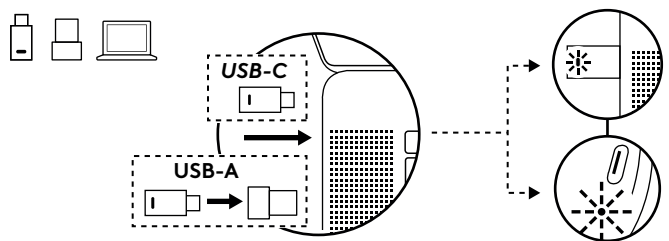

## PAREAMENTO VIA BLUETOOTH®

1. Deslize o botão liga/desliga até o ícone do Bluetooth® e segure por 2 segundos. O indicador de luz piscará rapidamente em branco.
2. Abra as configurações de Bluetooth® no seu dispositivo.
3. Selecione "Logi Zone Wireless 2 ES B2B" nos dispositivos detectáveis.
4. Uma vez pareado com sucesso, o indicador luminoso permanecerá branco estável.

### Dica (somente no Windows 10):

Quando o headset estiver pareado com o notebook, se necessário, acesse a configuração de som e selecione "Logi Zone Wireless 2 ES B2B Stereo" para obter a melhor qualidade de música e selecione "Logi Zone Wireless 2 ES B2B Hands-Free" para chamadas.

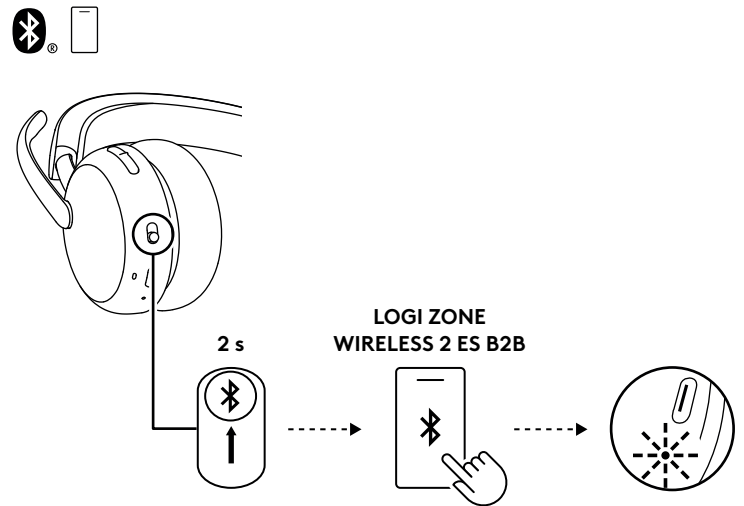

## AJUSTE DO HEADSET

1. Ajuste o headset deslizando os fones de ouvido para cima e para baixo no arco de cabeça.
2. Fones giratórios para encaixar no ouvido.
3. Pode ser mais fácil ajustar o fone de ouvido na cabeça. Mova os fones de ouvido para cima e para baixo no arco de cabeça até que eles se acomodem confortavelmente em seus ouvidos.

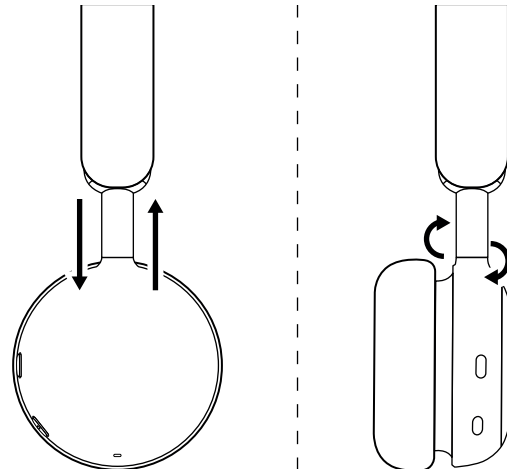

### AJUSTE O BRAÇO DO MICROFONE

O braço do microfone gira 270 graus. Use-o no lado esquerdo ou direito. O canal de áudio mudará automaticamente, dependendo da direção em que você estiver usando o microfone.

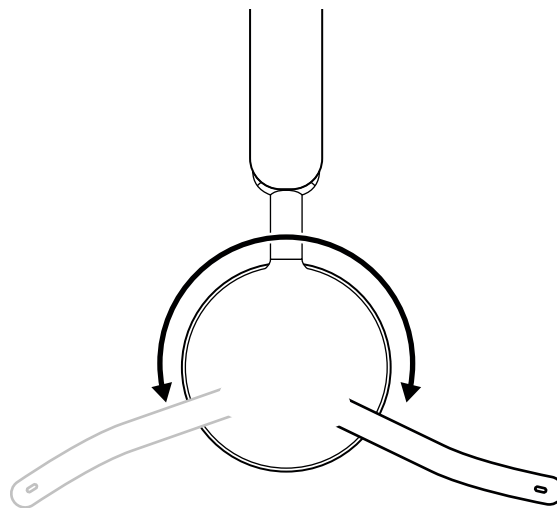

A haste do microfone deve ser colocada perto ou ao lado da boca, alinhada com o canto dela.



## CARREGANDO

O headset desliga automaticamente quando fica inativo.

O timer de suspensão pode ser alterado no aplicativo Logi Tune.

O indicador de luz do headset ficará VERMELHO quando a bateria estiver fraca.

## CARREGANDO VIA CABO USB

1. Conecte uma extremidade do cabo à porta *USB-C* na parte inferior do fone e a outra extremidade à porta de carregamento *USB-C* do computador, base ou adaptador de alimentação.
2. A luz indicadora será uma luz branca que pulsa ao carregar.
3. O indicador branco mudará para branco estável quando totalmente carregado.
  - 2 horas carregam totalmente a bateria.
  - 5 minutos de carregamento darão a você 1 hora de conversação.\*
4. O headset pode ser usado com um receptor e *Bluetooth*® pareado durante o carregamento. Ele também pode ser usado como um headset com fio com o *cabo USB-C* conectado enquanto o headset está desligado.

\*A duração da bateria pode variar de acordo com as condições ambientais e de computação.

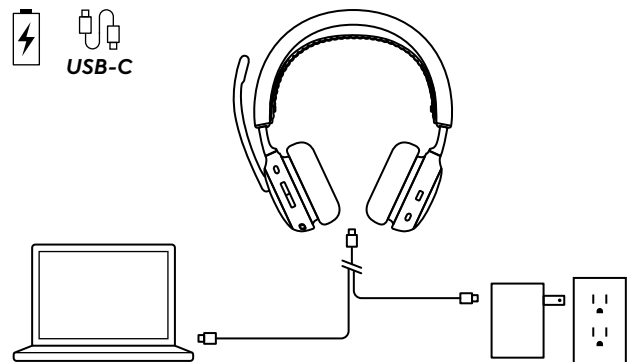

## CONTROLES NO HEADSET

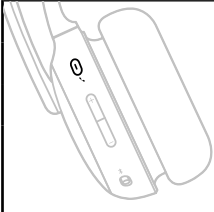
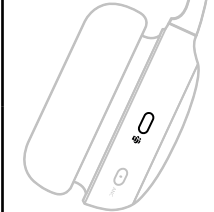
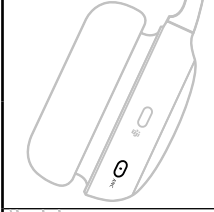
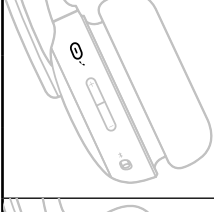
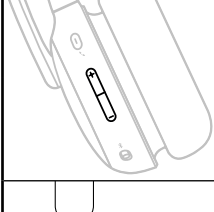
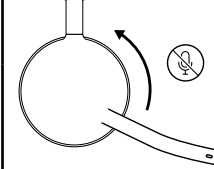
Botão	Uso		Ação
	<b>Controles de chamada</b>	Atender/Encerrar ligação	Pressione por tempo curto
		Retomar chamada em espera	
	<b>Assistência por voz</b>	Ativar assistente por voz (quando não há atividade de chamada)	Pressione por 2 segundos
	<b>Controles de chamada para o Teams (apenas para a versão do Teams)</b>	Atividades do Teams	Pressione brevemente
			Pressione por 2 segundos
	<b>Controles ANC</b>	Alternar entre ANC e transparência ativada	Pressione por tempo curto
		ANC desativado	Pressione por 2 segundos
	<b>Controles de mídia (Ative com o Logi Tune)</b>	Reproduzir/pausar	Pressione por tempo curto
		Próxima faixa	Pressionamento duplo
		Faixa anterior	Pressionamento triplo
	<b>Controles de volume</b>	Mais volume	Pressione brevemente para cima
		Menos volume	Pressione brevemente para baixo
	<b>Sem som</b>	Silêncio ativado	Braço do microfone levantado
		Silêncio desativado	Braço do microfone abaixado

### Observação:

- As atividades do Teams são funcionais apenas quando o Teams está sendo executado no computador desbloqueado.
- A funcionalidade de controle de mídia depende do tipo de aplicativo. Só pode ser configurado por meio do aplicativo Logi Tune.
- As atividades de chamadas são sempre a primeira prioridade em relação à transmissão de mídia. Quando dois dispositivos estão conectados, a conexão *Bluetooth*® terá prioridade sobre o receptor. Quando dois dispositivos *Bluetooth*® estão conectados, o último dispositivo ativo terá prioridade sobre o outro. A prioridade entre dois dispositivos *Bluetooth*® pode ser personalizada no aplicativo Logi Tune, em Dispositivos conectados.
- Para saber mais sobre o botão Teams, visite a página de suporte da *Microsoft*: Use o botão *Microsoft Teams* em seu dispositivo certificado para Teams.
- As notificações por voz indicam quando o microfone está ligado/desligado.

**Dica:** O ANC pode ser personalizado no aplicativo Logi Tune.

## CANCELAMENTO DE RUÍDO ATIVO (ANC)

O ANC bloqueia o ruído ao seu redor para ajudá-lo a se concentrar no trabalho.

- Pressione o botão ANC na lateral do fone para alternar entre os modos ANC e transparência.
- Haverá notificações por voz ao alternar entre os modos.

**Observação:** o botão ANC pode ser personalizado para alternar entre até cinco modos diferentes no aplicativo Logi Tune.

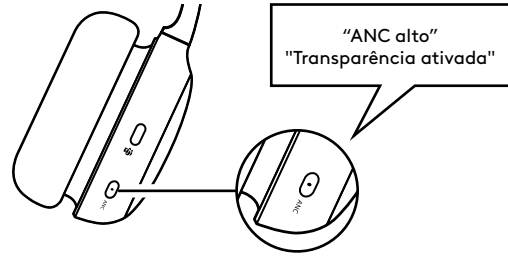

## INDICADOR DE NÍVEL DE BATERIA

Luz		Status
Branco	Estável	Ligar
		Conectado a um dispositivo
		Bateria totalmente carregada
	Pulsando	Bateria carregando
Piscando	Chamada recebida	
	Modo de emparelhamento Bluetooth®	
Vermelho	Piscando	Bateria fraca
	Estável	Sem áudio ativado
Roxo e branco	Piscando	Atualização do firmware do headset

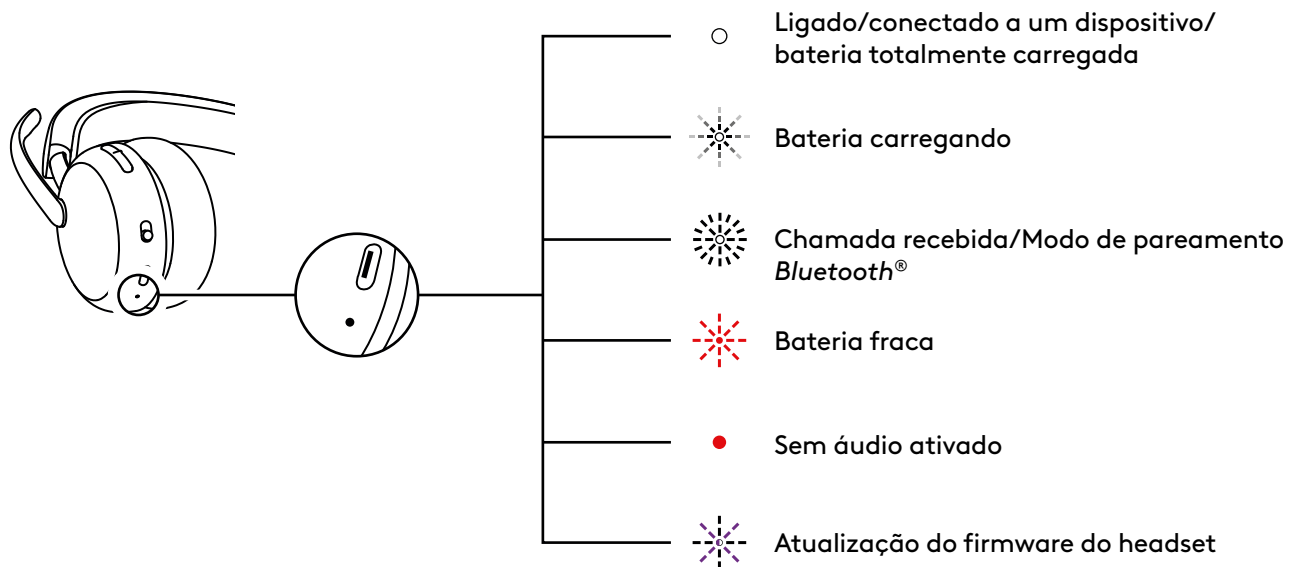

## LUZ INDICADORA DO RECEPTOR

Versão do Microsoft Teams		
	Luz	Status
<b>Branco</b>	Estável	Conectado
		Chamada em andamento
	Repetição intermitente ligada e desligada	Chamada recebida
<b>Roxo</b>	Estável	Conectado ao Teams
	Piscando	Conectando ao Teams/ notificações do Teams
	Piscando 3 vezes e apagado	Não conectado ao Teams
	Piscando por 10 segundos e desliga	Falha ao se conectar ao Teams
<b>Vermelho</b>	Estável	Sem áudio ativado
<b>Azul</b>	Brilhando	Pareamento

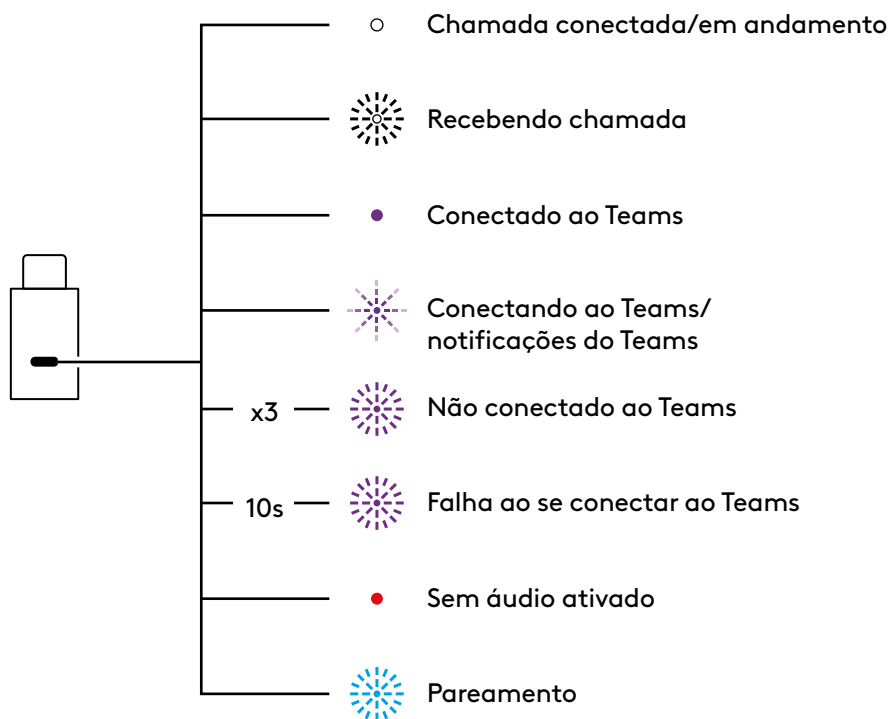

Versão UC		
Luz		Status
Branco	Estável	Conectado
	Repetição intermitente ligada e desligada	Chamada em andamento
Vermelho	Estável	Sem áudio ativado
Azul	Brilhando	Pareamento

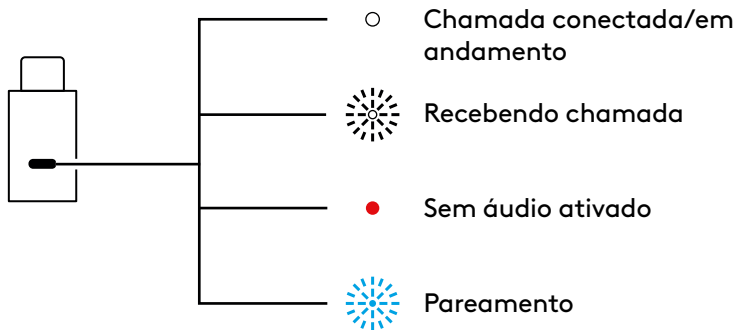

### ÁUDIO POR USB (AMIGÁVEL PARA DENSIDADE)

Se o áudio estiver instável durante uma chamada porque há muitos dispositivos sem fio próximos (alta densidade), o headset pode ser usado como um headset com fio.

1. Desligue o headset.
2. Conecte o headset ao cabo USB fornecido. E conecte o outro lado do cabo *USB -C* à porta *USB-C* do seu computador.
3. Certifique-se de que "Logi Zone Wireless 2 ES B2B-USB" esteja selecionado na configuração do dispositivo de áudio."

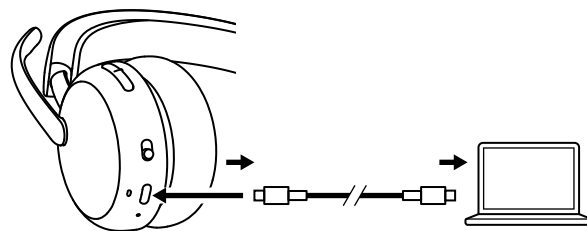

**Observação:** o headset seria carregado durante este modo. Os controles de botão podem não estar disponíveis neste modo.

## LOGI TUNE

O Logi Tune ajuda a aumentar o desempenho do headset com atualizações periódicas de software e de firmware. Saiba mais e baixe o Logi Tune em [logitech.com/tune](https://logitech.com/tune), na *Apple App Store* ou loja *Google Play*.



## AJUSTANDO SIDETONE

O Sidetone permite que você ouça sua própria voz durante as conversas, assim você fica ciente de quão alto está falando. No aplicativo Logi Tune, selecione o recurso sidetone e ajuste o seletor de acordo.

- Um número maior significa que você ouve mais som externo.
- Um número menor significa que você ouve menos som externo.

## TEMPORIZADOR DE SUSPENSÃO AUTOMÁTICA

Por padrão, o headset será desligado automaticamente quando não estiver em uso por 30 minutos. Ajuste o temporizador de suspensão no aplicativo Logi Tune.

## EQUALIZADOR DE MICROFONE

Personalize o equalizador do microfone no Logi Tune para ajustar sua voz e ela soar mais clara ou profunda.

## PROTEÇÃO AUDITIVA

O Zone Wireless 2 ES for Business oferece três tipos de proteção para ajudar você a ouvir com segurança.

**Limitação de pico:** O volume do áudio é sempre limitado a 100 dBA para evitar danos auditivos.

**Proteção contra choques acústicos:** Elimina picos de áudio repentinos para evitar choques acústicos de acordo com a diretriz australiana G616. Isso pode ser ativado no aplicativo Logi Tune e se aplica apenas a atividades de chamadas.

**Exposição a ruídos ao longo do tempo:** Protege seus ouvidos da exposição a ruídos por um período de 8 horas com um limite de até 85 dBA, conforme a diretriz australiana G616. Isso pode ser ativado no aplicativo Logi Tune e se aplica apenas a atividades de chamadas.

## ATUALIZE O HEADSET

Recomenda-se atualizar tanto o headset quanto o receptor. Para fazer isso, baixe o Logi Tune em [logitech.com/tune](https://logitech.com/tune) e verifique se há atualizações de firmware disponíveis.

**Observação:** desligue e ligue o headset após a conclusão da atualização para garantir que ela seja feita com êxito.

## RECONNECTE SEU HEADSET.

Caso o headset esteja desconectado do receptor, você pode reconectá-lo via Logi Tune.

1. Conecte o receptor *USB-C* ou o adaptador *USB-A* com o receptor *USB-C* à porta *USB* do computador.
2. Ligue o headset deslizando o botão liga/desliga para o centro.
3. Abra o Logi Tune Desktop no seu computador.
4. No painel, selecione "Receptor Zone".
5. Aguarde enquanto ele procura o headset conectado anteriormente.
6. Se nenhum headset for exibido como conectado ao receptor, clique em "Parear headset".
7. Entre no modo de pareamento no headset deslizando o botão liga/desliga até o ícone do *Bluetooth*<sup>®</sup> e segurando-o por 2 segundos. O indicador de luz piscará rapidamente em branco.
8. Quando pareado com sucesso, o indicador de luz no receptor e no headset ficará branco estável.

## REDEFINIÇÃO DO HEADSET

Para redefinir o headset de volta ao seu estado original, ligue o headset, mantenha pressionado o botão de aumentar o volume e deslize o botão liga/desliga no modo de pareamento por 5 segundos. O headset é redefinido com sucesso quando o indicador de luz do headset pisca três vezes, rapidamente, em vermelho e branco, e desliga.

## DIMENSÕES

### Headset:

Altura x largura x profundidade:  
185,2 x 183,6 x 73,0 mm

### Peso:

212 g

### Receptor:

Altura x largura x profundidade:  
26,8 x 12,4 x 6,2 mm

### Adaptador:

Altura x largura x profundidade:  
24,5 x 15,4 x 8,7 mm

## REQUISITOS DE SISTEMA

Compatível com aplicativos de chamada comuns em quase todas as plataformas e sistemas operacionais. Compatível com computadores com *Windows*, *Mac* ou *Chrome* via *USB-C*, *USB-A*, *Bluetooth*<sup>®</sup> e *iOS* ou dispositivos com *Android* e tecnologia *Bluetooth*<sup>®</sup>

## ESPECIFICAÇÕES TÉCNICAS

Tipo de microfone: Dois microfones com cancelamento de ruídos, algoritmos otimizados por IA e equalizador do microfone

Resposta de frequência (headset): 20 Hz a 20 kHz (modo de música), 100 Hz a 8 kHz (modo de conversa)

Resposta de frequência (microfone): 100 Hz a 8 kHz

Tipo de pilha: Bateria integrada (ion de lítio)

Duração da bateria (tempo de conversação)\*: Até 20 horas (ANC ativado), até 25 horas (ANC desativado)

Duração da bateria (tempo de escuta)\*: Até 25 horas (ANC ativado), até 48 horas (ANC desativado)

Versão do *Bluetooth*<sup>®</sup>: 5.3

Alcance sem fio\*: Até 50 m (linha de visão em campo aberto)

Comprimento do cabo de carregamento *USB-C* para C: 1,5 m

Conformidade de áudio: Em conformidade com a norma EN 50332-2

\*A vida útil da bateria e o alcance sem fio podem variar dependendo das condições ambientais e de computação.

[www.logitech.com/support/zonewireless2es-b](http://www.logitech.com/support/zonewireless2es-b)

# 瞭解您的產品

## 正面檢視

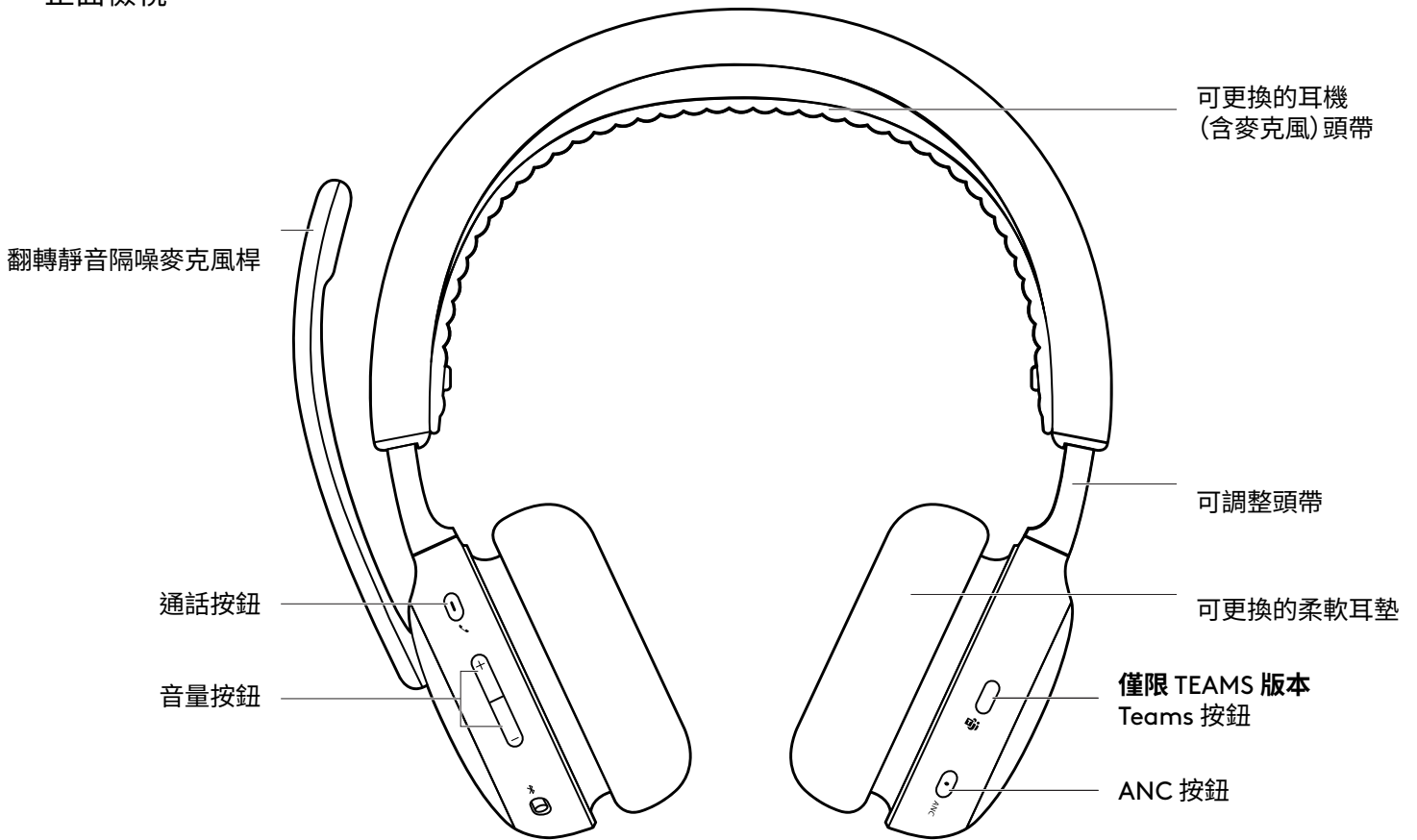

## 底部檢視

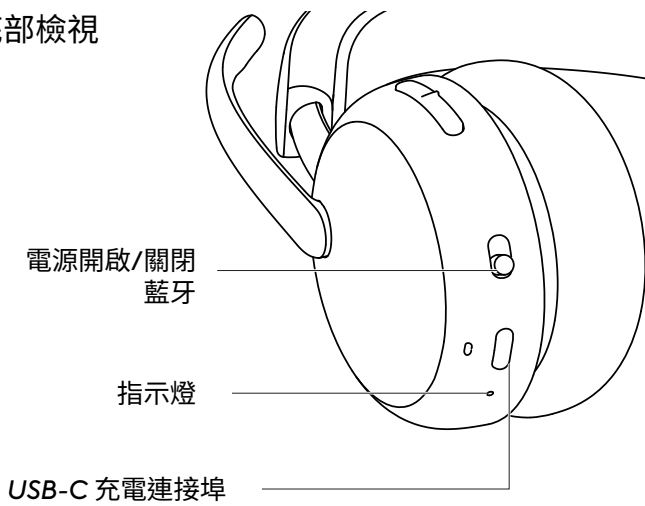

## USB 接收器和轉接器

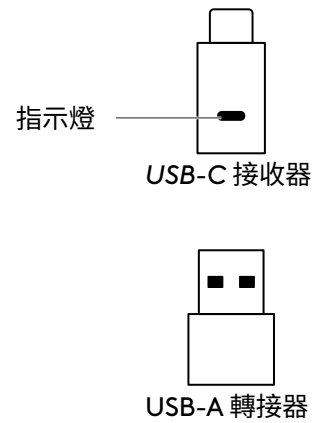

## 包裝內容

1. 耳機(含麥克風)
2. USB-C 接收器
3. USB-A 轉接器
4. USB-C 到 USB-C 充電連接線
5. 攜行袋
6. 使用者文件

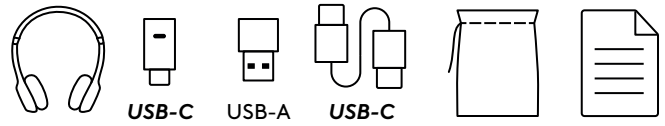

## 電源開啟/關閉

1. 將電源開關撥到中央位置。
2. 電源開啟時,指示燈會亮起白燈。
3. 若要關閉電源,請將電源開關撥到電源圖示位置。

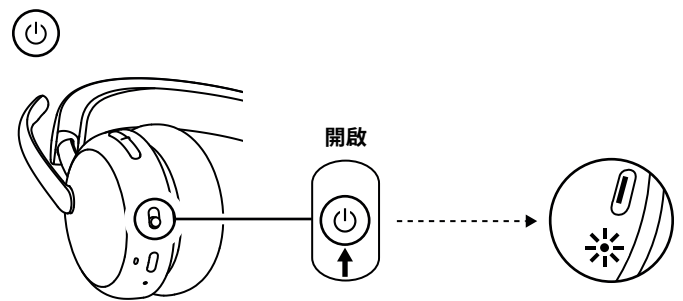

## 透過 USB 接收器配對

1. **USB-C**  
將接收器插入到電腦的 USB-C 連接埠。

### USB-A

將 USB-C 接收器插入到 USB-A 轉接器。然後將轉接器插入到電腦的 USB-A 連接埠。

2. 耳機(含麥克風)在發貨時,即已和其隨附的接收器配對。只需開啟耳機(含麥克風)電源。成功配對後,接收器上的指示燈會亮起穩定白燈。耳機(含麥克風)上的指示燈會亮起穩定白燈。
3. 確認在電腦聲音設定中選擇了「Logi Zone Wireless 2ES B2B」。

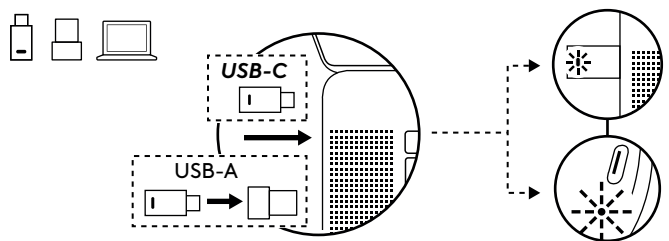

## 透過藍牙®配對

1. 將電源開關撥到藍牙™ 圖示位置，然後按住 2 秒。指示燈會快速閃爍白燈。
2. 開啟您裝置上的藍牙設定。
3. 在可發現裝置中選擇「Logi Zone Wireless 2 ES B2B」
4. 成功配對後，指示燈會亮起穩定白燈。

### 提示 (僅在使用 Windows 10 時):

耳機 (含麥克風) 與筆記型電腦配對時，如有需要，請前往聲音設定並選擇「Logi Zone Wireless 2 ES B2B 立體聲」以獲得最佳的音樂品質，通話用途則選擇「Logi Zone Wireless 2 ES B2B 免手持」。

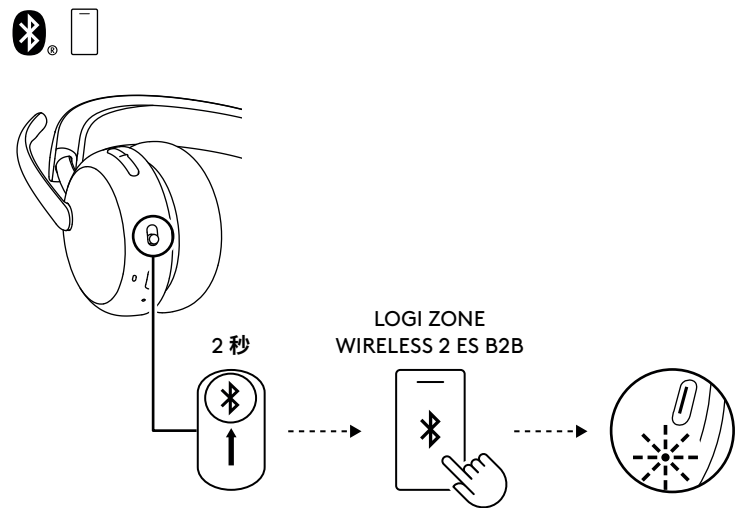

## 調整耳機 (含麥克風)

1. 耳機 (含麥克風) 的調整是透過在頭帶上下滑動耳罩來進行。
2. 旋轉耳罩以配合您的耳朵。
3. 可輕鬆調整耳機麥克風配戴在頭部的位置。將耳罩於頭帶上下滑動，直到其舒適的戴在您的耳朵上。

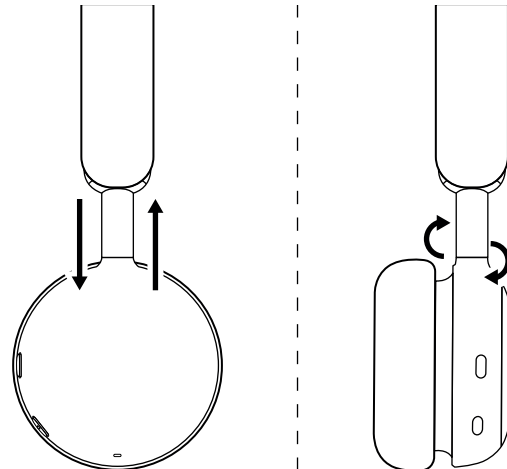

### 調整麥克風桿。

麥克風桿可旋轉 270 度。將其配戴在左側或右側。音訊頻道會視您配戴麥克風的方向自動切換。

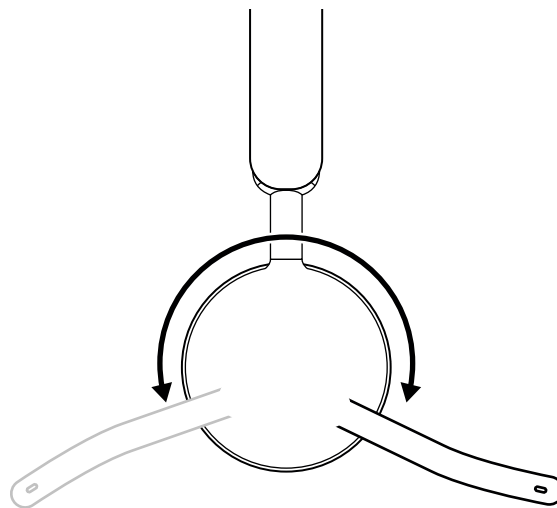

麥克風桿應放置在靠近或貼近您嘴巴的位置，並與嘴角對齊。



## 充電中

耳機(含麥克風)會在閒置時自動關閉電源。

在 Logi Tune 應用程式中可以變更休眠計時器。

耳機(含麥克風)上的指示燈會在電池電量偏低時亮起紅燈。

## 透過 USB 連接線充電

1. 將連接線的一端插入到耳罩底部的 USB-C 連接埠,另一段插入到電腦、底座或電源轉接器上的 USB-C 充電連接埠。
2. 指示燈會亮起白色呼吸燈指明正在充電。
3. 完全充電後指示燈會亮起穩定白燈。
  - 電池完全充電需要 2 小時時間。
  - 充電 5 分鐘可提供最多 1 小時通話時間\*。
4. 耳機(含麥克風)在充電時可搭配接收器和藍牙™ 配對裝置使用。在耳機(含麥克風)關閉電源時,也可使用連接的 USB-C 連接線來作為有線耳機(含麥克風)使用。

\*電池壽命會因環境與運算條件而有所不同。

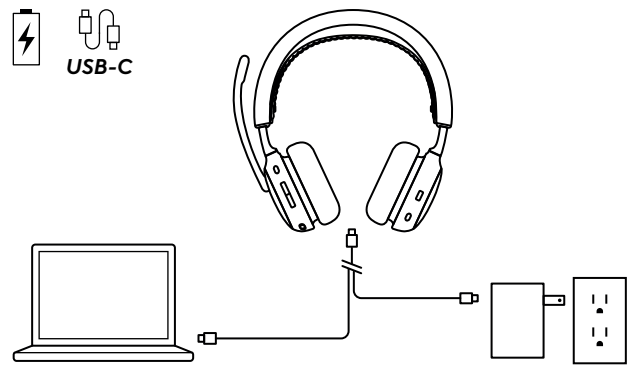

## 耳機(含麥克風)控制按鈕

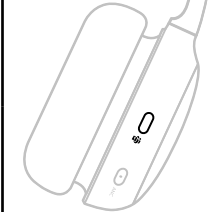
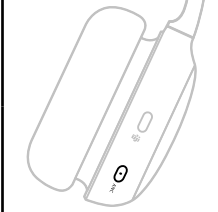
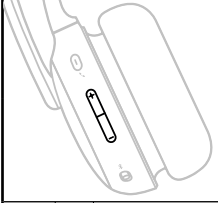
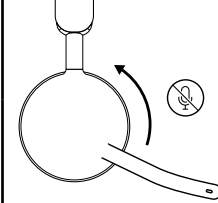
按鈕	用途		行動
	通話控制	接聽/掛斷通話	短按
		恢復保留中的通話	
	語音助理	觸發語音助理 (在沒有通話活動時)	按住 2 秒
	Teams 通話控制 (僅限 Teams 版本)	Teams 活動	短按
			按住 2 秒
	ANC 控制	在 ANC 與穿透模式間切換開啟	短按
		ANC 關閉	按住 2 秒
	媒體控制 (透過 Logi Tune 啟用)	播放/暫停	短按
		下一曲目	按兩下
		上一曲目	按三下
	音量控制	提高音量	短按向上
		調低音量	短按向下
	靜音	靜音開啟	將麥克風桿往上翻
		靜音關閉	將麥克風桿往下翻

### 注意：

- Teams 活動僅在 Teams 於未鎖定的電腦上執行時才可以使用。
- 媒體控制功能視應用程式類型而定。只能透過 Logi Tune 應用程式進行設定。
- 通話活動始終是優於媒體串流的第一優先選擇。連線到兩個裝置時，透過藍牙連線的裝置優先於透過接收器連線的裝置。有兩個連線的藍牙™ 裝置時，最後一個使用的裝置會優先於另一個裝置。兩個藍牙™ 裝置的優先順序，可在 Logi Tune 應用程式中的「連線裝置」中自訂。
- 若要了解更多關於 Teams 按鈕的資訊，請造訪 [Microsoft 支援頁面](#)：請在您獲得認證的 Teams 裝置，使用 Microsoft Teams 按鈕。
- 語音提示會在麥克風靜音開啟/關閉時告知狀態。

**提示：**ANC 可在 Logi Tune 應用程式中自訂。

## 主動隔噪 (ANC)

ANC 會阻隔您周圍的噪音，以協助您專心在手邊的工作上。

- 按下耳罩側邊的 ANC 按鈕可切換 ANC 和穿透模式。
- 在模式間切換時，會有語音提示告知狀態。

**注意：**ANC 按鈕可以在 Logi Tune 應用程式中自訂為在 5 種不同的模式間循環切換。

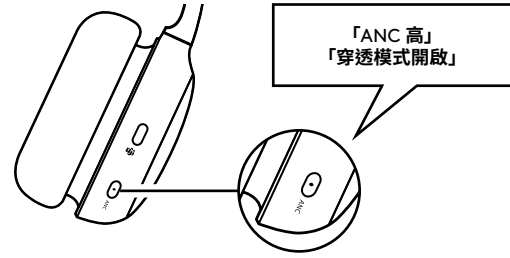

## 耳機 (含麥克風) 指示燈

輕		狀態
白燈	穩定亮起	開啟電源
		連線到裝置
	閃爍	電池已充滿
		電池充電
閃爍	來電	
	藍牙配對模式	
紅燈	閃爍	電池電力不足
	穩定亮起	靜音開啟
紫燈與白燈	閃爍	耳機 (含麥克風) 正在更新韌體

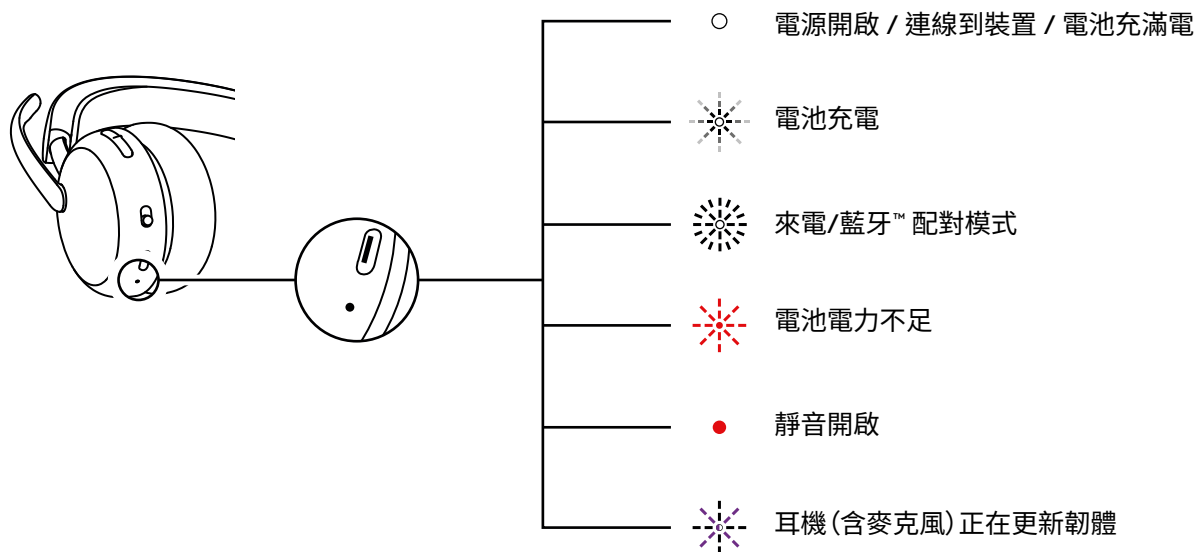

## 接收器指示燈

Microsoft Teams 版本		
	輕	狀態
白燈	穩定亮起	已連線 通話中
	重複閃爍亮起和熄滅	來電
紫燈	穩定亮起	已連線到 Teams
	閃爍	連線到 Teams / Teams 通知
	閃爍 3 次後熄滅	未連線到 Teams
	閃爍 10 秒後熄滅	無法連線到 Teams
紅燈	穩定亮起	靜音開啟
藍燈	閃爍	配對

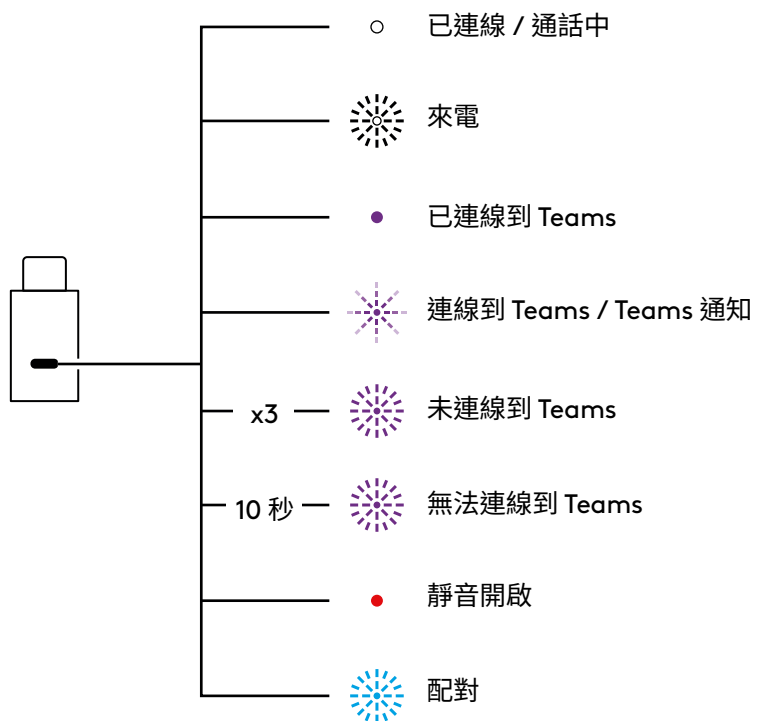

UC 版本		
輕		狀態
白燈	穩定亮起	已連線
	重複閃爍亮起和熄滅	通話中
紅燈	穩定亮起	來電
藍燈	閃爍	靜音開啟

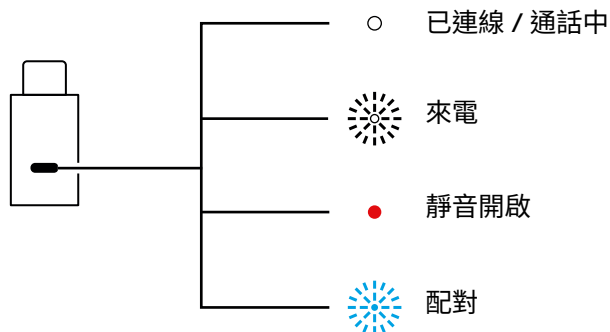

### USB 音訊 (適合高密度無線環境)

如果因為附近無線裝置過多 (高密度) 導致通話時音訊不穩定, 可將耳機 (含麥克風) 作為有線耳機 (含麥克風) 使用。

1. 關閉耳機 (含麥克風) 電源
2. 將耳機 (含麥克風) 連接到隨附的 **USB** 連接線。將 **USB-C** 連接線的另一端插入到您電腦上的 **USB-C** 連接埠。
3. 確認在音訊裝置設定中已選擇「Logi Zone Wireless 2 ES B2B-USB」。

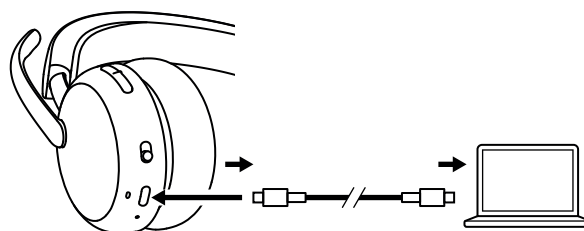

**注意:** 耳機 (含麥克風) 在此模式中會進行充電。在此模式中按鈕控制可能無法使用。

## LOGI TUNE

Logi Tune 可透過定期的軟體與韌體更新，協助加強耳機 (含麥克風) 性能。請到 [logitech.com/tune](https://logitech.com/tune)、[Apple App Store](#) 或 [Google Play](#) 下載 Logi Tune 並瞭解更多資訊。



### 調整側音

側音讓您可以在通話交談期間聽到自己的聲音，讓您知道您的講話有多大聲。在 Logi Tune 應用程式中，選擇側音功能，然後對轉鈕進行相應的調整。

- 數值較高表示您會聽到較多的外部聲音。
- 數值較低表示您會聽到較少的外部聲音。

### 自動休眠計時器

在預設情況下，您的耳機 (含麥克風) 會在 30 分鐘不使用後自動關閉電源。在 Logi Tune 應用程式中可調整此休眠計時器。

### 麥克風等化器

在 Logi Tune 中自訂麥克風等化器，將您的聲音調整得更明亮或更低沉。

### 聽力保護

Zone Wireless 2 ES for Business 提供三種類型的保護，協助您安全聆聽。

**峰值限制：**音訊音量始終限制在 100 dBA 以下，防止聽力受損。

**防護聲學震盪：**此功能根據澳大利亞 G616 指南，消除突然的音訊尖峰以避免聲學衝擊。此功能可在 Logi Tune 應用程式中啟用，且僅適用於通話活動。

**時段中的噪音暴露：**此功能根據澳大利亞 G616 指南，可以在 8 小時內保護您的耳朵避免噪音，最高為 85dBA。此功能可在 Logi Tune 應用程式中啟用，且僅適用於通話活動。

## 更新耳機(含麥克風)

建議您對耳機(含麥克風)和接收器兩者都進行更新。若要這麼做,請前往 [logitech.com/tune](https://www.logitech.com/tune) 下載 Logi Tune,然後檢查是否有可用的韌體更新。

**注意:** 在更新完成後關閉再開啟耳機(含麥克風)電源,以確認更新成功完成。

## 重新連線耳機(含麥克風)

如果耳機與接收器中斷連線,可以透過 Logi Tune 重新連線耳機(含麥克風)。

1. 將 USB-C 接收器或插入 USB-C 接收器的轉接器,插入到電腦的 USB 連接埠。
2. 將電源開關撥動到中央位置,開啟耳機(含麥克風)電源。
3. 在您的電腦上開啟 Logi Tune Desktop。
4. 從控制台中選擇「Zone Receiver」。
5. 等待程式尋找之前連線的耳機(含麥克風)。
6. 如果沒有顯示已連線到接收器的耳機(含麥克風),請按一下「配對耳機」。
7. 將電源開關撥動到藍牙™ 圖示位置並按住 2 秒,進入耳機(含麥克風)的配對模式。指示燈會快速閃爍白燈。
8. 成功配對後,接收器和耳機(含麥克風)上的指示燈會亮起穩定白燈。

## 重設耳機(含麥克風)

若要將耳機(含麥克風)重設為其原始狀態,請開啟耳機(含麥克風)電源,長按音量增加按鈕並將電源按鈕撥動至配對模式,並持續 5 秒。當耳機(含麥克風)指示燈快速閃爍紅燈 3 秒然後熄滅,耳機(含麥克風)即已成功重設。

## 尺寸

### 耳機(含麥克風):

高 x 寬 x 深:  
185.2 x 183.6 x 73.0 公釐

### 重量:

212 公克

### 接收器:

高 x 寬 x 深:  
26.8 x 12.4 x 6.2 公釐

### 轉接器:

高 x 寬 x 深:  
24.5 x 15.4 x 8.7 公釐

## 系統需求

可搭配幾乎所有平台和作業系統上的常見通話應用程式使用。可透過 USB-C、USB-A、藍牙™ 搭配 Windows、Mac 或 Chrome 電腦使用，並可搭配具藍牙™ 功能的 iOS 或 Android 裝置使用。

## 技術規格

麥克風類型：配備兩個具 AI 演算法與麥克風等化器的隔噪麥克風

耳機 (含麥克風) 頻率響應：20 Hz - 20 kHz (音樂模式)，100 Hz - 8 kHz (通話模式)

麥克風頻率響應：100 Hz - 8 kHz

電池類型：內建電池 (鋰電池)

電池使用壽命 (通話時間)\*：最長 20 小時 (ANC 開啟)，最長 25 小時 (ANC 關閉)

電池壽命 (聆聽時間)\*：最長 25 小時 (ANC 開啟)，最長 48 小時 (ANC 關閉)

藍牙版本：5.3

無線範圍\*：最遠 50 公尺 / 170 英尺 (視線可及的開放式場地)

USB-C 到 USB-C 充電連接線長度：1.5 公尺

音訊合規性：EN 50332-2 合規

\* 電池壽命與無線範圍視環境及運算條件而異。

[www.logitech.com/support/zonewireless2es-b](http://www.logitech.com/support/zonewireless2es-b)

# 제품 설명

## 전면

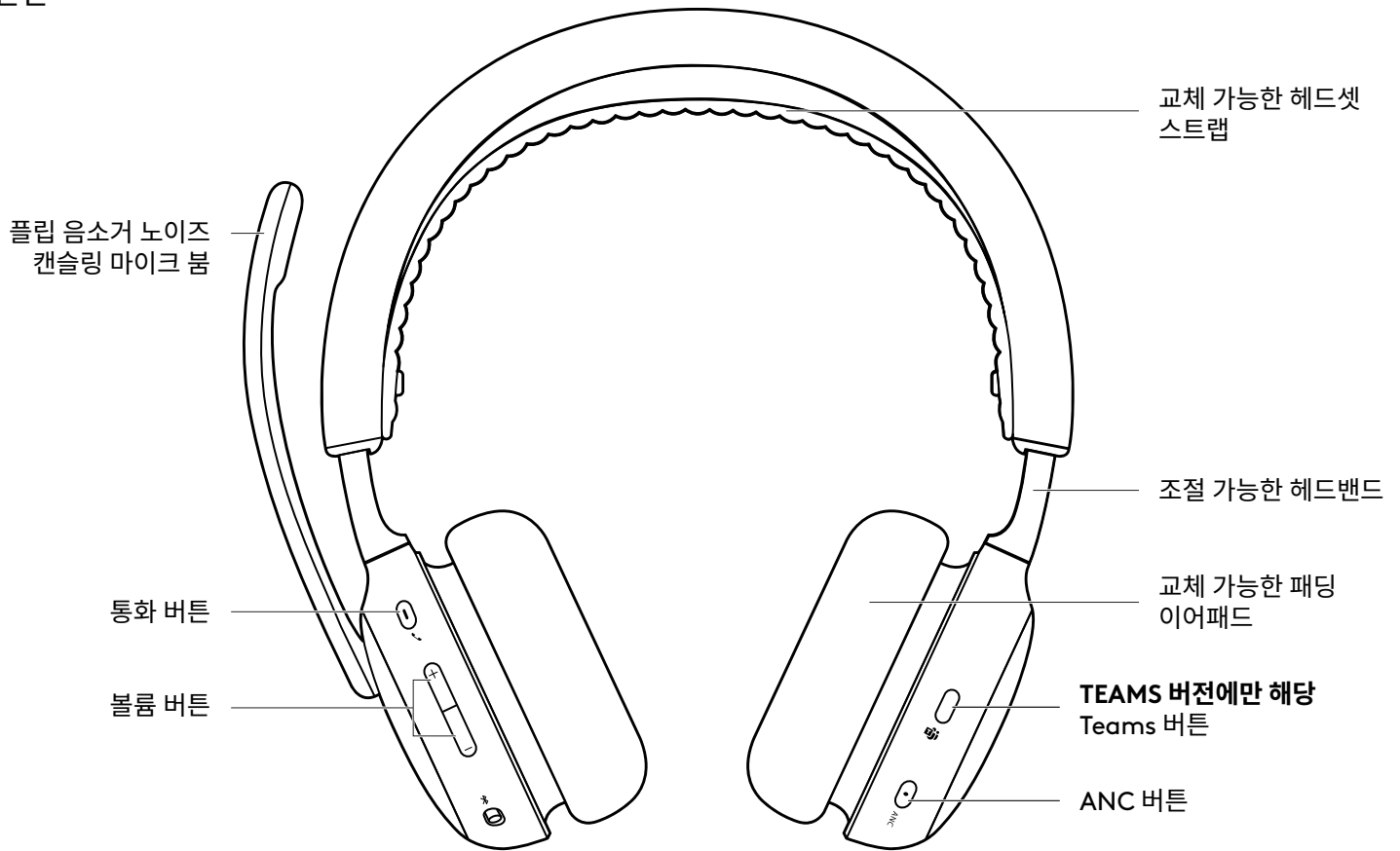

## 하단 모습

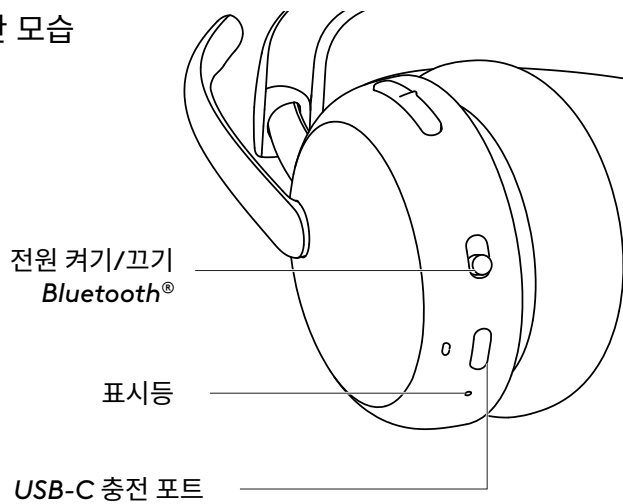

## USB 수신기 및 어댑터

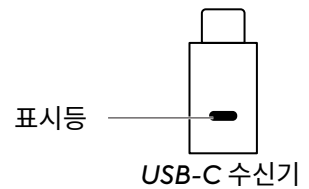

## 내용물

1. 헤드셋
2. USB-C 수신기
3. USB-A 어댑터
4. USB-C to C 충전 케이블
5. 휴대용 가방
6. 사용 설명서

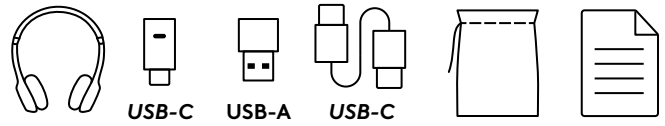

## 전원 켜기/끄기

1. 전원 스위치를 중앙으로 밀니다.
2. 전원이 켜지면 표시등이 흰색으로 변합니다.
3. 전원을 끄려면 전원 스위치를 전원 아이콘으로 밀니다.

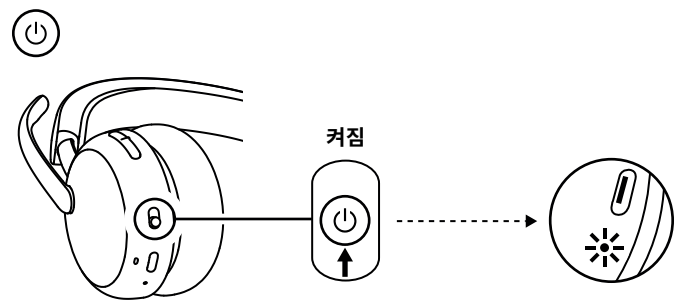

## USB 수신기 페어링

1. **USB-C**  
수신기를 컴퓨터의 USB-C 포트에 연결합니다.

### USB-A

USB-C 수신기를 USB-A 어댑터에 연결합니다. 그런 다음 컴퓨터 USB-A 포트에 어댑터를 삽입합니다.

2. 헤드셋은 함께 배송되는 수신기와 이미 페어링되어 있습니다. 그냥 헤드셋을 켭니다. 페어링이 성공적으로 완료되면 수신기의 표시등이 흰색으로 유지됩니다. 헤드셋의 표시등도 흰색으로 유지됩니다.
3. 컴퓨터 사운드 설정에서 "Logi Zone Wireless 2 ES B2B"가 선택되어 있는지 확인합니다.

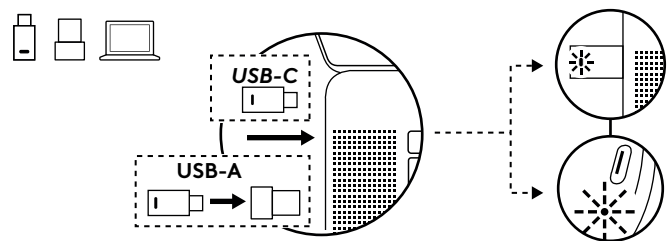

## BLUETOOTH® 페어링

1. 전원 스위치를 Bluetooth® 아이콘 쪽으로 밀고 2초 동안 유지합니다. 표시등이 빠르게 흰색으로 깜박입니다.
2. 장치에서 Bluetooth® 설정을 엽니다.
3. 검색 가능한 장치에서 "Logi Zone Wireless 2 ES B2B"를 선택합니다.
4. 페어링이 성공적으로 완료되면 표시등이 흰색으로 유지됩니다.

### 팁(Windows 10에서만 해당):

헤드셋이 노트북에 페어링되었을 때, 필요한 경우 사운드 설정으로 이동한 뒤 "Logi Zone Wireless 2 ES B2B Stereo"를 선택하면 최상의 음질을 즐길 수 있으며, "Logi Zone Wireless 2 ES B2B Hands-Free"를 선택하면 통화할 수 있습니다.

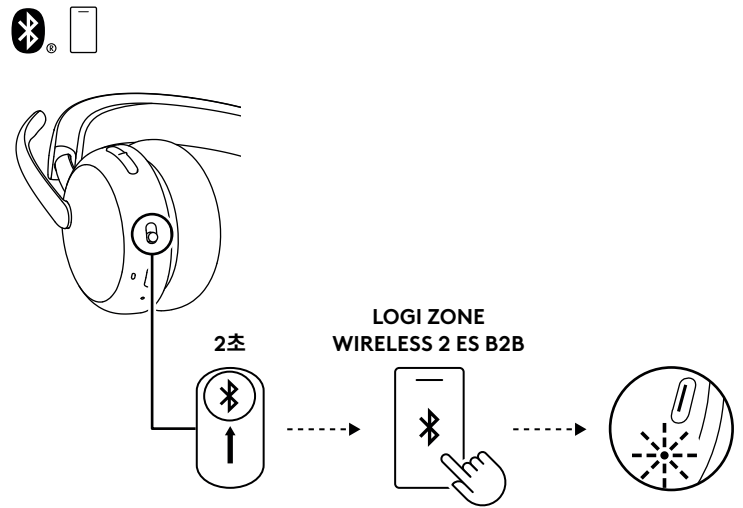

## 헤드셋 조절

1. 헤드밴드의 이어컵을 위아래로 밀어서 헤드셋을 조절합니다.
2. 이어컵을 귀에 맞게 돌립니다.
3. 머리에 쓴 채로 조절하면 더 간편한 조절이 가능합니다. 이어컵이 귀에 편안하게 안착될 때까지 헤드밴드를 위아래로 움직여 줍니다.

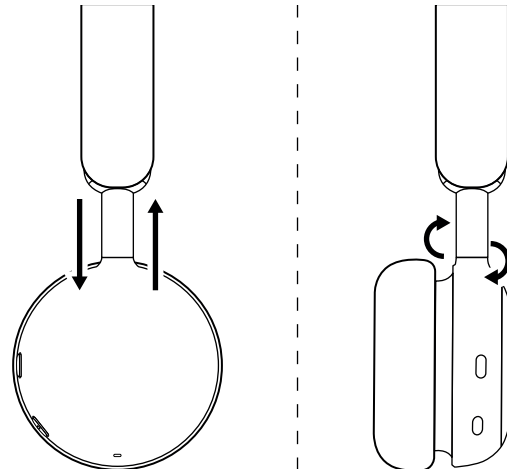

### 마이크 붐 조절

마이크 붐은 270도 회전 가능합니다. 왼쪽 또는 오른쪽에 착용할 수 있습니다. 마이크 착용 방향에 따라 오디오 채널이 자동으로 전환됩니다.

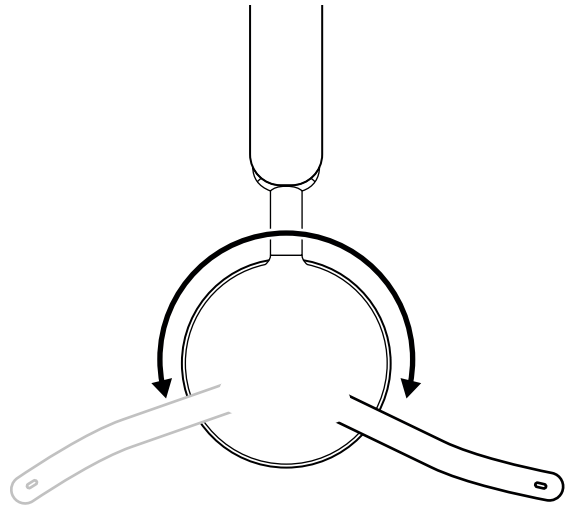

마이크 붐은 입에 가까이 또는 옆에 두어 입 가장자리와 일직선이 되도록 해야 합니다.

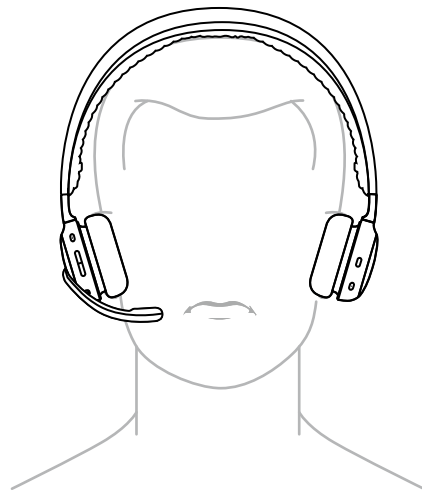

## 충전 중

헤드셋을 사용하지 않으면 자동으로 전원이 꺼집니다.

Logi Tune 앱에서 절전 타이머를 변경할 수 있습니다.

배터리가 부족하면 헤드셋 표시등이 빨간색으로 바뀝니다.

## USB 케이블을 통한 충전

1. 이어컵 하단에 있는 *USB-C* 포트에 케이블 한 쪽 끝을 연결하고 컴퓨터의 *USB-C* 충전 포트, 도크 또는 전원 어댑터에 다른 쪽 끝을 연결합니다.
2. 충전 시 표시등이 흰색으로 천천히 깜빡입니다.
3. 완전히 충전되면 LED가 흰색으로 유지됩니다.
  - 2시간 동안 충전하면 배터리가 완전히 충전됩니다.
  - 5분 충전으로 1시간의 통화가 가능합니다.\*
4. 헤드셋은 수신기 및 *Bluetooth*®로 페어링된 상태라면 충전 중에도 사용할 수 있습니다. 헤드셋의 전원이 꺼져도 *USB-C* 케이블을 연결하면 유선 헤드셋으로 사용할 수 있습니다.

\*배터리 수명은 주변 환경 및 컴퓨터 사용 조건에 따라 다를 수 있습니다.

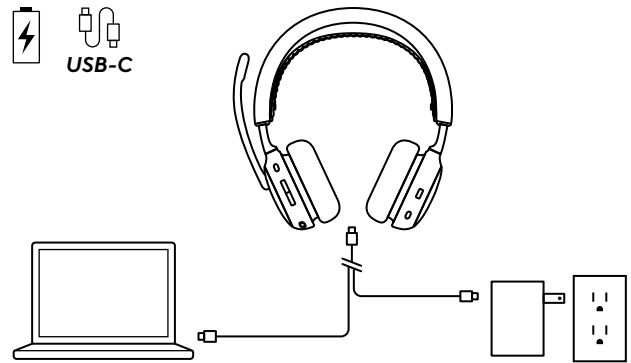

## 헤드셋 컨트롤

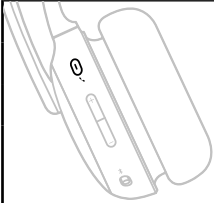
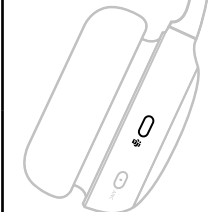
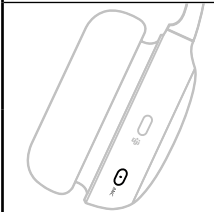
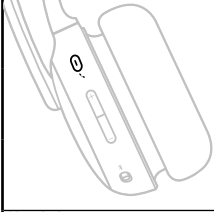
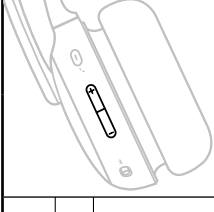
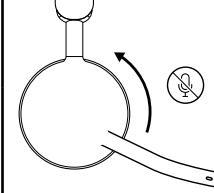
단추	용도		조치
	<b>통화 컨트롤</b>	응답 / 통화 종료	짧은 누르기
		대기 중인 통화 재개	
	<b>음성 도우미</b>	음성 도우미 불러오기 (통화 중이 아닐 때)	2초 누르기
	<b>Teams 통화 컨트롤 (Teams 버전에만 해당)</b>	Teams 활동	짧게 누르기
	<b>ANC 컨트롤</b>	ANC 및 투명 전환	짧은 누르기
		ANC 꺼짐	2초 누르기
	<b>미디어 컨트롤 (Logi Tune으로 활성화)</b>	재생 / 일시 중지	짧은 누르기
		다음 트랙	두 번 누르기
		이전 트랙	세 번 누르기
	<b>볼륨 컨트롤</b>	볼륨 높이기	짧게 위로 누르기
		볼륨 줄이기	짧게 아래로 누르기
	<b>음소거</b>	음소거 켜짐	마이크 붐을 위로 올리기
		음소거 꺼짐	마이크 붐을 아래로 내리기

### 참고:

- Teams 활동은 잠겨 있지 않은 컴퓨터에서 Teams를 사용 중일 때만 작동됩니다.
- 미디어 컨트롤 기능은 애플리케이션 유형에 따라 달라집니다. Logi Tune 앱을 통해서만 설정할 수 있습니다.
- 통화 활동은 미디어 스트리밍보다 항상 최우선입니다. 장치가 두 개 연결되면 Bluetooth® 연결이 수신기를 통한 연결보다 우선입니다. 두 개의 Bluetooth® 장치가 연결된 경우, 마지막으로 활성화된 장치가 우선입니다. Logi Tune 앱의 연결된 장치에서 두 Bluetooth® 장치 간의 우선순위를 커스터마이징할 수 있습니다.
- Teams 버튼에 대한 자세한 내용은, Microsoft 지원 페이지를 참조하세요. 인증된 Teams 장치에서 Microsoft Teams 버튼을 사용할 수 있습니다.
- 음성 알림이 마이크 음소거 켜짐/꺼짐 상태를 알려줍니다.

팁: Logi Tune 앱에서 ANC를 커스터마이징할 수 있습니다.

## 액티브 노이즈 캔슬링(ANC)

ANC는 작업에 집중할 수 있도록 주변 소음을 차단합니다.

- 이어컵 측면에 있는 ANC 버튼을 눌러 ANC와 투명 모드 사이를 전환할 수 있습니다.
- 모드 전환 시 음성으로 알려줍니다.

**참고:** Logi Tune 앱에서 ANC 버튼이 최대 5개의 모드 사이를 순환하도록 설정할 수 있습니다.

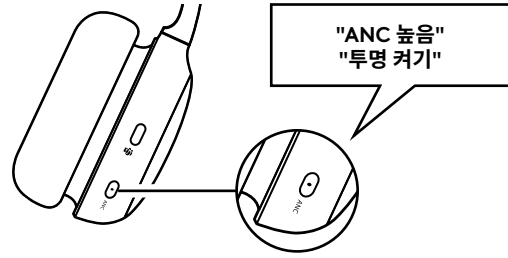

## 헤드셋 표시등

표시등		상태
흰색	계속 켜짐	전원 켜짐
		장치에 연결됨
		배터리 충전 완료
	깜박임	배터리 충전 중
		걸려온 통화 Bluetooth® 페어링 모드
빨간색	깜박임	배터리 부족
	계속 켜짐	음소거 켜짐
보라색 및 흰색	깜박임	헤드셋 펌웨어 업데이트 중

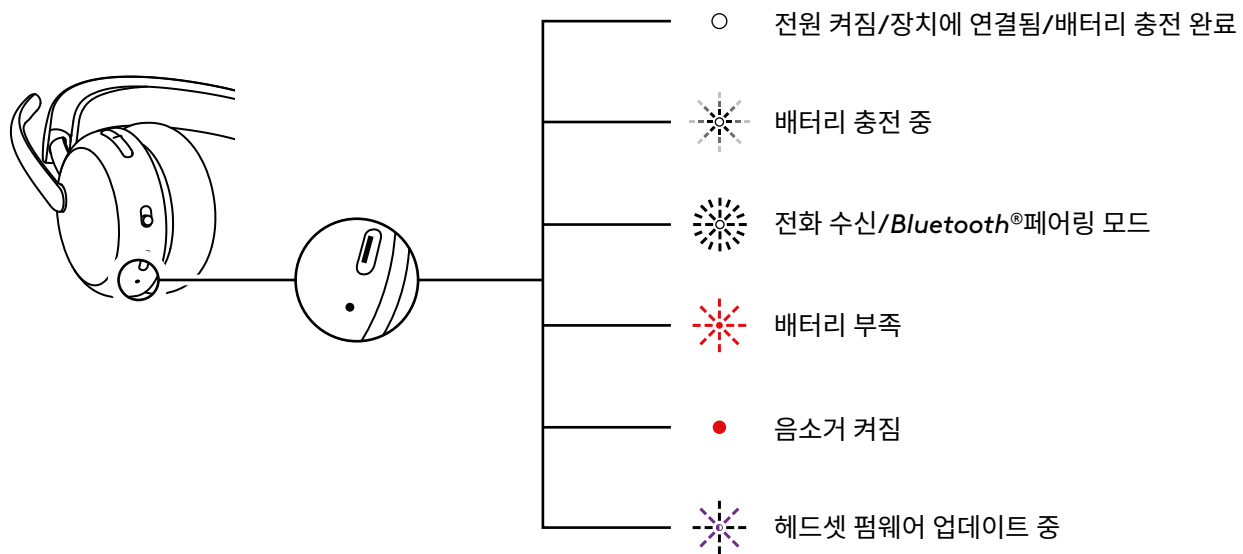

## 수신기 표시등

Microsoft Teams 버전		
표시등		상태
흰색	계속 켜짐	연결됨
		통화 중
	점멸 반복	걸려온 통화
자주색	계속 켜짐	Teams 연결됨
	깜박임	Teams / Teams 알림 연결
	3번 깜박인 뒤 꺼짐	Teams 연결되지 않음
	10초 동안 깜박임	Teams 연결 실패
빨간색	계속 켜짐	음소거 켜짐
파란색	깜박임	페어링

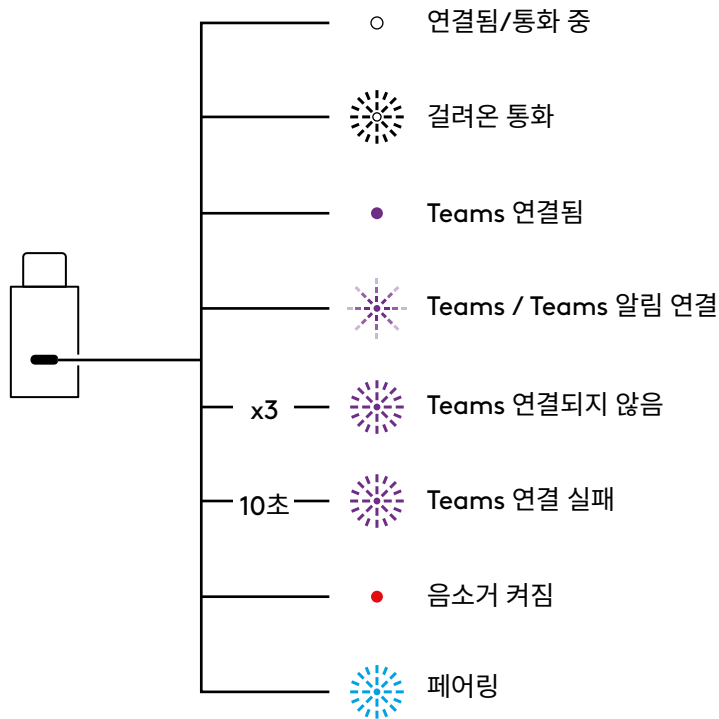

UC 버전		
표시등		상태
흰색	계속 켜짐	연결됨
	점멸 반복	통화 중
빨간색	계속 켜짐	걸려온 통화
파란색	깜박임	음소거 켜짐

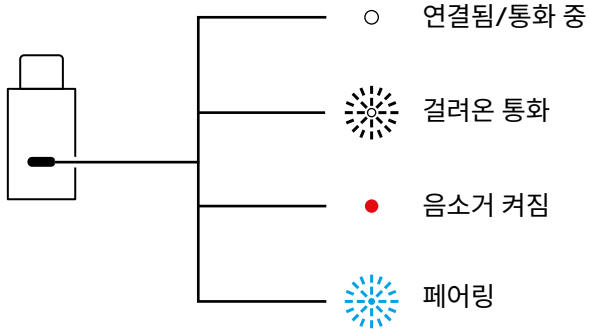

### USB 오디오(고밀도 환경에 추천)

주변에 무선 장치가 너무 많아(고밀도) 통화 중 오디오가 불안정한 경우, 유선 헤드셋으로 사용할 수 있습니다.

1. 헤드셋을 끕니다.
2. 제공된 USB 케이블에 헤드셋을 연결합니다.  
USB-C 케이블의 반대편을 컴퓨터의 USB-C 포트에 연결합니다.
3. 오디오 장치 설정에서 "Logi Zone Wireless 2 ES B2B-USB"가 선택되어 있는지 확인합니다.

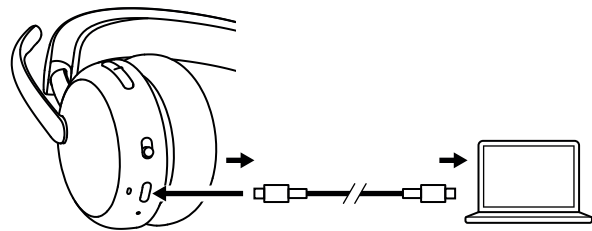

**참고:** 이 모드에서는 헤드셋이 충전됩니다. 이 모드에서는 버튼 컨트롤을 사용하지 못할 수도 있습니다.

## LOGI TUNE

Logi Tune은 정기 소프트웨어 및 펌웨어 업데이트로 헤드셋 성능 향상을 지원합니다. [logitech.com/tune](https://logitech.com/tune), *Apple App Store* 또는 *Google Play* 스토어에서 Logi Tune에 대해 자세히 알아보고 다운로드할 수 있습니다.



### 사이드톤 조절

대화하는 동안 자신의 목소리를 들을 수 있게 해줌으로써 자신이 얼마나 큰 소리로 말하고 있는지를 인식하게 해줍니다. Logi Tune 앱에서 측음 기능을 선택하고 알맞게 다이얼을 조절합니다.

- 숫자가 높을수록 외부 소리가 더 크게 들립니다.
- 숫자가 낮을수록 외부 소리가 더 작게 들립니다.

### 자동 절전 타이머

기본적으로 30분 동안 사용하지 않으면 헤드셋의 전원이 자동으로 꺼집니다. Logi Tune 앱에서 절전 타이머를 조절할 수 있습니다.

### 마이크 EQ

Logi Tune의 마이크 EQ를 사용자 지정하여 목소리가 더 밝거나 깊게 들리도록 조절할 수 있습니다.

### 청력 보호

Zone Wireless 2 ES for Business는 안전한 청취를 위하여 세 가지 유형의 보호 기능을 제공합니다.

**피크 제한:** 청력 손상을 방지하기 위해 오디오 볼륨은 항상 100dBA로 제한됩니다.

**음향 충격에 대한 보호:** 오스트레일리아 G616 지침에 따라 갑작스러운 오디오 스파이크를 제거하여 음향 충격을 방지합니다. 이는 Logi Tune 앱에서 활성화할 수 있으며 통화 활동에만 적용됩니다.

**시간 경과에 따른 소음 노출:** 오스트레일리아 G616 지침에 따라 최대 85dBA 한도로 8시간 동안 소음 노출로부터 귀를 보호합니다. 이 기능은 Logi Tune 앱에서 활성화할 수 있으며 통화 활동에만 적용됩니다.

## 헤드셋 업데이트

헤드셋과 수신기를 모두 업데이트하는 것이 좋습니다. 업데이트하려면, [logitech.com/tune](https://www.logitech.com/tune)에서 Logi Tune을 다운로드하고 사용 가능한 펌웨어 업데이트를 확인합니다.

**참고:** 업데이트 완료 후 헤드셋을 껐다 켜서 정상적으로 적용되었는지 확인합니다.

## 헤드셋 다시 연결

헤드셋이 수신기에서 분리된 경우, Logi Tune을 통해 헤드셋을 다시 연결할 수 있습니다.

1. USB-C 수신기 또는 USB-C 수신기 탑재 USB-A 어댑터를 컴퓨터 USB 포트에 연결합니다.
2. 전원 스위치를 중앙으로 밀어 헤드셋의 전원을 켭니다.
3. 컴퓨터에서 Logi Tune 데스크탑을 엽니다.
4. 대시보드에서 "Zone 수신기"를 선택합니다.
5. 이전에 연결된 헤드셋을 찾는 동안 기다립니다.
6. 수신기에 연결된 헤드셋이 표시되지 않으면, "헤드셋 페어링하기"를 클릭합니다.
7. 헤드셋에서 전원 스위치를 Bluetooth® 아이콘 쪽으로 밀고 2초간 길게 눌러 페어링 모드에 진입합니다. 표시등이 빠르게 흰색으로 깜박입니다.
8. 페어링이 성공적으로 완료되면 수신기와 헤드셋의 표시등이 흰색으로 유지됩니다.

## 헤드셋 초기화

헤드셋을 원래 상태로 초기화하려면, 헤드셋 전원이 켜진 상태에서 볼륨 높이기 버튼을 길게 누르고 전원 버튼을 페어링 모드 쪽으로 5초 동안 밀니다. 헤드셋 표시등이 빨간색과 흰색으로 빠르게 3번 깜박인 후 꺼지면 헤드셋이 성공적으로 초기화된 것입니다.

## 치수

### 헤드셋:

높이 x 너비 x 높이:  
185.2 x 183.6 x 73.0mm

### 무게:

212g

### 수신기:

높이 x 너비 x 높이:  
26.8 x 12.4 x 6.2mm

### 어댑터:

높이 x 너비 x 높이:  
24.5 x 15.4 x 8.7mm

## 시스템 요구 사항

대부분의 플랫폼 및 운영 체제에서 일반적으로 사용되는 통화 애플리케이션을 지원합니다. *Windows*, *Mac*, 또는 *Chrome* 기반 컴퓨터에서 *USB-C*, *USB-A*, *Bluetooth®*를 통해 이용할 수 있으며, *iOS* 또는 *Android* 기기에서도 *Bluetooth®* 지원 시 이용 가능합니다.

## 기술 사양

마이크 유형: AI 기반 알고리즘과 마이크 EQ를 탑재한 2개의 노이즈 캔슬링 마이크

주파수 응답(헤드셋): 20Hz~20 kHz(음악 모드), 100Hz~8kHz(대화 모드)

주파수 응답(마이크): 100Hz~8kHz

배터리 유형: 내장 배터리(리튬 이온)

배터리 수명(통화 시간)\*: 최대 20시간(ANC 켜짐), 최대 25시간(ANC 꺼짐)

배터리 수명(청취 시간)\*: 최대 25시간(ANC 켜짐), 최대 48시간(ANC 꺼짐)

*Bluetooth®* 버전: 5.3

무선 범위\*: 최대 50m/170ft(개방 공간)

*USB-C to C* 충전 케이블 길이: 1.5m

오디오 규정 준수: EN 50332-2 규격

\*배터리 수명은 주변 환경 및 컴퓨터 사용 조건에 따라 다를 수 있습니다.

[www.logitech.com/support/zonewireless2es-b](http://www.logitech.com/support/zonewireless2es-b)

© 2025 Logitech. Logitech, Logi, Zone, and their logos are trademarks or registered trademarks of Logitech Europe S.A. and/or its affiliates in the U.S. and other countries. *Apple*, the *Apple* logo, *iOS*, and *Mac* are trademarks of Apple Inc., registered in the U.S. and other countries. *App Store* is a service mark of Apple Inc. *Android*, *Chrome*, *Google Play* and the *Google Play* logo are trademarks of Google LLC. The *Bluetooth*<sup>®</sup> word mark and logos are registered trademarks owned by Bluetooth SIG, Inc. and any use of such marks by Logitech is under license. *Microsoft Teams* and *Windows* are trademarks of the Microsoft group of companies. *USB-C* and all other 3rd party trademarks are the properties of their respective owners. Logitech assumes no responsibility for any errors that may appear in this manual. Information contained herein is subject to change without notice.

© 2025 Logitech. Logitech, Logi, Zone et leurs logos sont des marques commerciales ou déposées de Logitech Europe S.A. et/ou de ses filiales aux États-Unis et dans d'autres pays. *Apple*, le logo *Apple*, *iOS* et *Mac* sont des marques d'Apple Inc., déposées aux États-Unis et dans d'autres pays. *App Store* est une marque de service d'Apple Inc. *Android*, *Chrome*, *Google Play* et le logo *Google Play* sont des marques de Google LLC. Le mot et les logos *Bluetooth*<sup>®</sup> sont des marques déposées détenues par Bluetooth SIG, Inc. et sont utilisés par Logitech sous licence. *Microsoft Teams* et *Windows* sont des marques du groupe de sociétés Microsoft. *USB-C* et toutes les autres marques déposées tierces sont la propriété exclusive de leurs détenteurs respectifs. Logitech décline toute responsabilité en cas d'erreurs susceptibles de s'être glissées dans le présent manuel. Les informations énoncées dans ce document peuvent faire l'objet de modifications sans préavis.