

AS/NZS 4282:2023



Australian/New Zealand Standard™

Control of the obtrusive effects of outdoor lighting



AS/NZS 4282:2023

This Joint Australian/New Zealand Standard ® was prepared by LG-010, Obtrusive Effects Of Outdoor Lighting. It was approved on behalf of the Council of Standards Australia on 29 September 2023 and by the New Zealand Standards Approval Board on 04 October 2023.

This Standard was published on 3 November 2023.

The following are represented on Committee LG-010:

Astronomical Society of Australia
Auckland Transport
Brisbane City Council
CIE Australia
Consumers Federation of Australia
Department of Climate Change, Energy, the Environment and Water
Energy Networks Australia
Engineers Australia
IES: The Lighting Society
Institute of Public Works Engineering Australasia
Lighting Council Australia
Lighting Council New Zealand
Municipal Association of Victoria
Outdoor Media Association
University of Sydney
Waka Kotahi-NZ Transport Agency

This Standard was issued in draft form for comment as DR AS/NZS 4282:2022.

Keeping Standards up-to-date

Ensure you have the latest versions of our publications and keep up-to-date about Amendments, Rulings, Withdrawals, and new projects by visiting:

www.standards.org.au

www.standards.govt.nz

ISBN 978 1 76139 370 9

Australian/New Zealand Standard™

Control of the obtrusive effects of outdoor lighting

Originated in Australia as AS 4282(Int)—1995.
Jointly revised and designated as AS/NZS 4282:2019.
Second edition 2023.

© Standards Australia Limited/the Crown in right of New Zealand, administered by the New Zealand Standards Executive 2023

All rights are reserved. No part of this work may be reproduced or copied in any form or by any means, electronic or mechanical, including photocopying, without the written permission of the publisher, unless otherwise permitted under the Copyright Act 1968 (Cth) or the Copyright Act 1994 (New Zealand).

Preface

This Standard was prepared by the Joint Standards Australia/New Zealand Committee LG-010, Obtrusive Effects of Outdoor Lighting, to supersede AS/NZS 4282:2019.

The objective of this document is to provide a basis for assessment of the potential obtrusiveness of the effects from an outdoor lighting system. However, it should be noted that the potentially obtrusive effects of the lighting will normally be only one of a number of environmental and ecological considerations that will need to be addressed during a development assessment. Conformance to this document, i.e. conformance to the limits for the various light technical parameters defined in this document, will therefore not necessarily be the sole basis for the approval of particular development proposals.

The following are significant changes between this edition and the previous edition:

- (a) The assessment of lighting of lit vertical surfaces including internally and externally illuminated signs, façades or objects has been modified.
- (b) The position of the calculation planes has been clarified, changed to better define the difference between current and future dwelling locations and also provide a buffer zone for environmentally sensitive areas.
- (c) This document does not apply to public lighting unless specified by the relevant authority. Limits have been included in [Section 4](#) of this edition when required. Thus, obtrusive light can be controlled in areas where it might be seen as a problem without the need to calculate the impact of every public lighting luminaire.
- (d) Environmental receivers are now considered under the Standard. This change recognizes the impact that artificial light at night can have on plants, animals and ecosystems. The limits identified in [Tables 3.2](#) to [3.4](#) apply to environmental receivers as well as human receivers. Conformity to this document will benefit environmental receivers through a reduction in spill light, but will not necessarily ameliorate impacts where protected species and communities are located on, or adjacent to the site.
- (e) The application of environmental zones has been clarified; it considers the ambient environment for the lighting system and/or each affected property as appropriate.
- (f) The assessment of sports venues illuminated for TV coverage has been modified.
- (g) The veiling luminance [Equation 3.2](#) has been changed.

Formally recognized sensitive locations, such as Siding Spring Observatory (Australia) and Aoraki Mackenzie International Dark Sky Reserve (New Zealand) may have requirements in addition to this document. This document does not address all the requirements that may be necessary for the lighting system to facilitate specific activities for which it is designed. Reference should be made to the appropriate Standard, such as such as AS/NZS 1158 series for the lighting for roads and public spaces, AS/NZS 1680.5 for outdoor workplace lighting and the AS 2560 series for sports lighting.

Where environmental impacts are likely, reference should be made to the following documents as applicable:

UN Environment Programme Convention on the Conservation of Migratory Species of Wild Animals. Light Pollution Guidelines: UNEP/CMS/Resolution 13.5/Annex.

National Light Pollution Guidelines for Wildlife: Including marine turtles, seabirds and migratory shorebirds.

NOTE The United Nations document is based on the Australian document.

The lighting system may also be subject to approvals of other authorities such as aviation, road safety, and environmental approvals, that are additional to the requirements of this document.

The terms “normative” and “informative” have been used in this document to define the application of the appendix to which they apply. A “normative” appendix is an integral part of a Standard, whereas an “informative” appendix is only for information and guidance.

Contents

Preface	ii
Introduction	v
Section 1 Scope and general	1
1.1 Scope.....	1
1.2 Normative references.....	2
1.3 Terms and definitions.....	2
1.4 Demonstration of conformity.....	7
Section 2 Potential obtrusive effects	8
2.1 General.....	8
2.2 Influence of surrounding context.....	8
2.3 Specific effects.....	8
2.3.1 Effects on residents.....	8
2.3.2 Effects on transport system users.....	9
2.3.3 Effects on transport signalling systems.....	9
2.3.4 Effects on the night sky (sky glow).....	9
2.3.5 Effects on the natural environment.....	11
Section 3 Light technical parameters	12
3.1 General.....	12
3.2 Limits for light technical parameters.....	12
3.2.1 Applicable limits.....	12
3.2.2 Applicable light technical parameters.....	13
3.2.3 Basis for differentiation of limits according to area type.....	13
3.2.4 Basis for differentiation of limits for E_v and I according to times of operation.....	14
3.2.5 Basis for differentiation of limits for luminous intensity (I) according to precedent.....	14
3.3 Assessment of conformance.....	15
3.3.1 Environmental Zones A0-A4.....	15
3.3.2 Sport and event venues illuminated for TV coverage.....	22
3.3.3 Lit surfaces.....	23
Section 4 Public lighting	27
4.1 General.....	27
4.2 Assessment of conformance.....	27
4.3 Public lighting zones.....	27
4.3.1 Basis for differentiation of limits according to zone type.....	27
4.3.2 Public lighting zones for public lighting schemes as determined by AS/ NZS 1158.3.1.....	27
4.4 Limits for light technical parameters.....	28
Section 5 Use of computer programs	29
Appendix A (informative) Design, installation, commissioning and maintenance guidelines	30
Appendix B (informative) Design documentation	40
Appendix C (informative) Impact of outdoor lighting on flora and fauna	42
Appendix D (informative) Lighting of flags and banners	45
Appendix E (informative) Field measurements	48
Bibliography	52

Introduction

This document provides methods and limits to control the obtrusiveness of outdoor lighting that may be spilling from a lighting system.

With any outdoor lighting system, it is not always possible to contain all light within the boundaries of the property on which it is installed. Some light may spill outside the property boundaries, either directly or by reflection. The determination of when the spill light becomes obtrusive to others is difficult since both physiological and psychological effects are involved. Irrespective, spill light should be limited where possible within the limits of the lighting function.

Government plays an important role in controlling the obtrusive effects of outdoor lighting through the approvals process, and in resolving neighbourhood disputes involving residents who experience discomfort or annoyance from nearby outdoor lighting systems. Government authorities may apply restrictions on the frequency of use and hours of operation of outdoor lighting, and on the levels of light spilled beyond the boundaries of the subject site.

Several aspects of potential obtrusiveness are considered, including the light falling on surrounding properties, the brightness of luminaires in the field of view of nearby residents, the glare to users of adjacent transport systems, the effects on astronomical observations and the impact on environmentally sensitive areas. For the control of these effects, limiting values of the light technical parameters have been developed taking account of the following:

- (a) The level of lighting consistent with the development zoning approved for the area.
- (b) The times that the proposed lighting is to operate.
- (c) The type of lighting technology available to light the task.
- (d) The use of readily available and easily understood technical data on the lighting systems that can easily be verified at the design and assessment stages.

These criteria have been utilized to ensure that the document is both credible to the interested parties and pragmatic in application.

Limiting values of illuminance at windows and of the intensity of bright light sources, necessary to satisfy the large majority of people as being at all times unobtrusive, are rather low. Furthermore, these values can easily be exceeded with conventional lighting practice, especially if the area of activity being lit is large and the required light level is relatively high.

There are potentially conflicting requirements for dark-hours activity and the maintenance of amenity and environmental integrity, therefore, two sets of limiting values are given dependent on the levels of lighting already in the area. One, with higher values, is for application outside the curfew time set by local government and the other, with lower values, is for application during the curfew period. Most outdoor sports lighting systems likely to be subject to this document are expected to operate only outside the curfew period.

The less restrictive values are predicated on dark time activity taking place while giving passive recipients of spill light relief from it being excessively obtrusive. The limiting values are based on the use of conventional lighting technology but with good practice being used in the selection of appropriate lighting levels, luminaires and aiming practices.

The more restrictive values, applying during the curfew period, are predicated on the maintenance of amenity and environmental integrity being the dominant considerations. The spill light at these times should be such that it will not be obtrusive to the large majority of recipients. To achieve this goal the need for the proposed lighting and its operation during the curfew period should be considered in the first instance. If the lighting is required to be operational during the curfew period, then careful attention needs to be given to the limitation of spill light. The type of luminaires (i.e. light distribution) and their specific locations and aiming angles, and the need for the fitting of louvres, baffles or shields needs careful evaluation.

Although public lighting is not within the scope of this document, light technical parameter limits have been included where the relevant authority considers that the extent and level of obtrusive light should be limited. The limits recognize that such lighting is provided to facilitate safety and security for the public at large.

The limits identified in this document have not been derived to address specific species or ecological community needs and so conformance with this document may not be sufficient to meet environmental regulation.

Australian/New Zealand Standard

Control of the obtrusive effects of outdoor lighting

Section 1 Scope and general

1.1 Scope

The objective of this document is to provide a common basis for assessment of the potential obtrusiveness of the effects from the lighting of developments that involve the provision of outdoor lighting. It includes limits for the relevant light technical parameters to control these effects. As the obtrusive effects of outdoor lighting are best controlled by appropriate design, this document is primarily applicable to new systems. This document specifically refers to the potentially adverse effects of outdoor lighting on nearby residents (e.g. of dwellings such as houses, hotels, hospitals), transport system users (e.g. pilots, water craft operators, train drivers, motorists, cyclists), transport signalling systems (e.g. air, marine, rail), astronomical observations and environmentally sensitive areas.

The document does not apply to the following:

- (a) Lighting for entertainment and festivals that is designed for a performance or an event that operates outside of curfew hours, and for a regularly occurring event that operates for an interval of not more than 30 min each night, excluding sports lighting.
- (b) Emergency warning, way finding lights/marker lights, navigation lights, all traffic signals, traffic signage and vehicle headlights, including working lights mounted on moving vehicles and plant.
- (c) Lighting for aviation safety.
- (d) Flags that are required to be lit at night by government protocol, see [Appendix D](#).

This document does not apply to the following unless specified by the relevant authority:

- (i) Public lighting, as defined in [1.3.24](#). (see [Section 4](#)).
- (ii) Temporary lighting other than that stated in item (a), operating for less than one month,

This document does not apply to the following unless the lighting scheme impacts environmentally sensitive areas, or observatories:

- (A) Lighting chains and other small lighting systems and devices, for example budlighting, fairy lights, festoon lighting, where the individual lights emit less than 30 lm and has a total luminous flux of less than 20 000 lm that operates in the non-curfew period.
- (B) The upward light limits for lighting of approved public artworks.
- (C) The upward light limits for lighting of the facades of classified heritage buildings and objects.

This document does not apply to temporary sports lighting, including that for televised coverage.

The above exemptions do not override regulatory and environmental legislation.

This document does not apply to impacts associated with the aesthetic or obtrusive daytime appearance of outdoor lighting systems, including their support structures.

While conformance with this document will afford general environmental benefit by reducing sky glow and light spill, the management of artificial light for the protection of specific entities protected by environmental legislation is beyond the scope of this document due to the diversity of impact pathways, species-specific behavioural and physiological responses of organisms and ecosystems to artificial light, and the potential for listed entities to be found in all environmental zones. As there are no agreed light thresholds at which it has been demonstrated that protected species will not be significantly impacted, biological monitoring would be required to demonstrate that the objectives of

environmental legislation had been met. Environmental impact assessment is beyond the scope of this document. Where protected entities are likely to be significantly impacted by artificial light, a risk-assessed and adaptive management approach should be undertaken to assess the impacts to protected species or ecological communities. Further guidance for environmental impact assessment is provided in [Appendix C](#).

This document is intended for reference by the following:

- (1) Relevant operators and authorities; such as building and infrastructure owners, industry plant operators, planning bodies, local government and transport control authorities etc, to assist in assessing and mitigating the potential obtrusiveness of both shielded and unshielded outdoor lighting systems.
- (2) Specifiers, designers, and installers of outdoor lighting systems, as an aid to producing lighting systems that control obtrusive effects to limits defined in this document.

NOTE [Appendix B](#) provides guidance on the documentation that may be required by planning bodies, in order to facilitate assessment of a proposed lighting scheme.

1.2 Normative references

The following documents are referred to the text in such a way that some or all of their content constitutes requirements of this document.

NOTE Documents for informative purposes are listed in the Bibliography.

AS ISO/IEC 17025, *General requirements for the competence of testing and calibration laboratories*

AS/NZS 1158.1.1, *Lighting for roads and public spaces, Part 1.1: Vehicular Traffic (Category V) lighting-Performance and design requirements*

AS/NZS 1158.2, *Lighting for roads and public spaces, Part 2: Computer procedures for the calculation of light technical parameters for Category V and Category P lighting*

AS/NZS 1158.3.1, *Lighting for roads and public spaces, Part 3.1: Pedestrian Area (Category P) lighting-Performance and design requirements*

AS/NZS 1158.4, *Lighting for roads and public spaces, Part 4: Lighting of pedestrian crossings*

NZS ISO/IEC 17025, *General requirements for the competence of testing and calibration laboratories*

1.3 Terms and definitions

For the purpose of this document, the following terms and definitions apply.

1.3.1

affected property

property, with one or more relevant boundaries, where the obtrusive impact from the lighting system is being assessed; or, for environmental receivers; their habitat, or that part of their habitat in which the obtrusive impact from the lighting system is being assessed

1.3.2

beam angle

angle between two imaginary lines in a plane through the [optical beam axis](#), such that these lines pass through the centre of the front face of the device and through points at which the [luminous intensity](#) is 50 % of the [centre beam intensity](#)

Note 1 to entry: The beam angle is a full angle measure, not a half angle measure.

Note 2 to entry: The beam angle is expressed in degrees (°).

1.3.3

building façade

external face of a building that is visible from a calculation plane or a road or of a building at or near an astronomical observing facility

1.3.4

car parks-outdoor

1.3.4.1

off-road car park

area either on grade or on a structure that is on a separate land title to the road reserve and is designed for the parking of vehicles and includes defined entries, exits, and access roads

1.3.4.2

on-road car parking

parking on the road reserve including parallel, angle and median parking

1.3.5

commercial area

area that is zoned for commercial, industrial or shared commercial and residential purposes

1.3.6

competent person

person who has acquired, through education, training, qualification, or experience, or a combination of these, the knowledge and skill enabling that person to perform the task required

1.3.7

control direction

with respect to the luminaire, direction that has a declination at a given vertical angle below the horizon

Note 1 to entry: This is a representative direction, with respect to a luminaire's light distribution, that is used for the purpose of evaluating conformance to the maximum luminous intensities.

Note 2 to entry: See [Figure 3.3](#).

1.3.8

curfew

time interval during which stricter requirements for the control of [obtrusive light](#) apply

Note 1 to entry: See [Clause 3.2.1](#).

1.3.9

dwelling

building, or part thereof, in which people reside, especially during the hours of darkness

Note 1 to entry: For example, house, hotel, motel, hospital.

1.3.10

dynamic content

where the luminous image, pattern, colour or direction of light changes over an interval of less than 60 seconds

1.3.11

environmentally sensitive area

area of ecological value including, bushland, waterways and marine and coastal areas

Note 1 to entry: These areas may be in any environmental zone and include areas that are unlit and should remain dark to provide refuge for flora and fauna that require naturally dark environments. These may include green/black-belts through urban environments.

1.3.12**environmental zone**

categorisation of the relative ambient lighting and environmental conditions as relevant to the lighting system or affected property

1.3.13**environmental receiver**

any identified living species (plants, animals and other organisms) and their locations indicated, that may be impacted by the proposed lighting system

1.3.14**façade lighting**

light sources for external decorative purposes that are fixed to the façade, embedded in the building elements or immediately behind the glazing

1.3.15**floodlight**

specific type of luminaire that emits light within a restricted range of directions, i.e. a beam

1.3.16**glare**

condition of vision in which there is discomfort or a reduction in ability to see, or both, caused by an unsuitable distribution or range of luminance, or to extreme contrasts in the field of vision

1.3.16.1**disability glare**

glare that impairs the visibility of objects without necessarily causing discomfort

1.3.16.2**discomfort glare**

glare that causes discomfort without necessarily impairing the visibility of objects

Note 1 to entry: Both disability and discomfort glare may be present concurrently.

1.3.17**habitable room**

room within a dwelling that is occupied by people for extended periods, especially at night

Note 1 to entry: For example, living room, bedroom and study but not bathroom or storage room.

1.3.18**lighting system**

lighting system comprises the light sources, luminaires or luminous signs, facades and artworks, that are part of the proposed, changed or existing installation that is being assessed

1.3.19**luminaire**

apparatus which distributes, filters or transforms the light transmitted from at least one source of optical radiation and which includes, except the sources themselves, all the parts necessary for fixing and protecting the sources and, where necessary, circuit auxiliaries together with the means for connecting them to the power supply

1.3.20**may**

indicates the existence of an option

1.3.21**obtrusive light**

[spill light](#) which, because of quantitative or directional attributes, gives rise to annoyance, discomfort, distraction, or a reduction in ability to see essential information such as transport signals

Note 1 to entry: Obtrusive light includes the impact on humans and environmental receivers.

1.3.22**outdoor lighting**

any exterior or interior lighting that emits directly into the outdoor environment

1.3.23**protected species and ecological communities**

species or ecological communities listed under the *Environment Protection and Biodiversity Act 1999* as threatened or migratory; or as a protected matter under Australian state or territory environmental legislation; or listed under New Zealand's *Conservation Act 1987*

1.3.24**public lighting**

lighting provided for the purposes of safety and security on public roads, cyclist paths, footpaths and pedestrian movement areas within public parks and gardens, including on-road car parking, but not including off-road car parks

Note 1 to entry: Requirements for public lighting are set out in the AS/NZS 1158 series.

1.3.25**public lighting zones**

categorisation of Public Lighting for the assessment of the impact on adjacent properties, where required by the relevant authority

1.3.26**recreational areas**

areas designated for active play, leisure or public assembly such as parks, picnic grounds, camp sites, golf courses, lakes, streams, and oceans, but excluding private residential areas and sports facilities with dedicated sports lighting

1.3.27**reference direction**

direction to which the luminous intensity distribution of a luminaire is referred

Conventionally, this may be the direction that is normal to the front glass (or luminous emitting surface), the maximum luminous intensity or, where there is no unique maximum, the direction of the centre of the light beam, see [Figure 3.3](#)

1.3.28**relevant authority**

organization or individual who has the legal responsibility to make a determination, approval or exemption for a specific aspect of the obtrusive assessment

1.3.29**relevant boundary**

any boundary of a residential property or environmentally sensitive area over which it is physically possible for spill light from the lighting system to pass and directly impact on—

- (a) a dwelling located on the affected property;
- (b) the potential site of a dwelling if there is no development on the affected property; or
- (c) an area designated as environmentally sensitive area

Note 1 to entry: The lighting system may be within the relevant property boundary.

1.3.30**shall**

indicates that a statement is mandatory

1.3.31**should**

indicates a recommendation

1.3.32**sign**

internally or externally illuminated signage (directional and/or advertising) including static and dynamic signage (e.g. digital billboards), whether mounted outdoors or mounted within a building and visible to an external observer

1.3.33**solid state lighting****SSL**

type of [lighting](#) that uses semiconductor [LEDs](#), organic LEDs (OLEDs), polymer LEDs (PLEDs) or laser diodes as [sources](#) of lighting

1.3.34**sky glow**

brightening of the night sky that results from the [reflection](#) of radiation (visible and non-visible), scattered from the constituents of the atmosphere (gas molecules, aerosols and particulate matter), in the direction of observation

1.3.34.1**man-made sky glow**

part of the [sky glow](#) that is attributable to man-made sources of radiation (e.g. outdoor lighting)

1.3.34.2**natural sky glow**

part of the [sky glow](#) that is attributable to radiation from celestial [sources](#) and luminescent processes in the Earth's upper atmosphere

1.3.35**spill light**

light emitted by a [lighting installation](#) that falls outside the boundaries of the property for which the [lighting installation](#) is designed

Note 1 to entry: Spill light may not necessarily be obtrusive.

1.3.36**threshold increment****TI**

measure of [disability glare](#) expressed as the percentage increase in [luminance contrast](#) threshold required between an object and its background for it to be seen equally well with a source of [glare](#) present

Note 1 to entry: Increasing values of threshold increment correspond to increasing [disability glare](#).

Note 2 to entry: The threshold increment has unit one.

1.3.37**tilt angle**

angle in the vertical plane from nadir (the downward vertical axis directly beneath) to the vector that the luminaire reference direction is aimed. The tilt and uplift angle may be the same, e.g. for a road luminaire, or a symmetrical beam floodlight

Note 1 to entry: Uplift is the angle of the reference surface of the luminaire (usually the light emitting surface or housing) with respect to the horizon. The uplift angle may be different to the tilt where the distribution of the luminaire is asymmetric. The uplift angle may be positive or negative. Refer to AS 2560.2 for more detail.

Note 2 to entry: See [Figure 3.3](#).

1.3.38**upward light ratio****1.3.38.1****upward light ratio (luminaire)****ULR_L**

ratio of the luminous flux of a luminaire that is emitted, at and above the horizontal, divided by the total luminaire flux when the luminaire is mounted in its designed position

1.3.38.2**upward light ratio (system)****ULR_S**

ratio of the luminous flux of all luminaires in the system that is emitted directly into the night sky, divided by the total flux of all the luminaires, when the luminaire(s) is (are) mounted in its designed position(s), and excluding reflected light from surfaces or obstructions

Note 1 to entry: This method allows the inclusion of the impact of obstructions such as baffles or awnings to be included.

1.4 Demonstration of conformity

Conformance to this document shall be demonstrated by the results of calculations and analysis of design methods with respect to the relevant Light Technical Parameters (LTPs) set out herein.

Measurement is not required for conformance.

Section 2 Potential obtrusive effects

2.1 General

This section provides guidance on effects that outdoor lighting may have on surrounding areas.

Outdoor lighting while intended for a specific purpose may have some adverse effect on persons and the environmental receivers. For example, some activities require the illumination of an object in a volume or space, and not just of a surface at ground level. Note that generally there will be a diffusion of light within the lit space resulting from the reflection from surfaces. The following examples illustrate this point:

- (a) Lighting for certain sports, e.g. tennis, baseball, cricket or golf driving ranges where it is essential to be able to see the movement of the ball in the space above the playing surface to an appropriate height.
- (b) Lighting a freight terminal where it is necessary to identify containers in multiple container stacks.
- (c) Security lighting at or adjacent to the property boundary.

NOTE 1 See [Appendix A](#) for guidance on the design and operation of lighting systems.

2.2 Influence of surrounding context

The obtrusive effects of the lighting system may be significantly influenced by the following factors:

- (a) The use of the area abutting or in close proximity to the proposed development.
- (b) The topography of the area surrounding the lighting system. Residential developments at a lower level than that of the lighting system are more likely to be subjected to a direct view of the luminaires.
- (c) Physical features such as adjacent buildings, trees and spectator stands, that may be effective in restricting light spill beyond the boundaries of the development.
- (d) The existing ambient lighting characteristics relative to the proposed lighting.
- (e) The location of the proposed development relative to—
 - (i) areas of special significance, e.g. areas having cultural, environmental, historical or scientific importance;
 - (ii) harbours, airports, heliports, waterways, roads or railway systems where spill light from the proposed development may interfere with the visibility of signalling or signage associated with them; or
 - (iii) community and scientific optical observatories where spill light from the proposed development may interfere with astronomical observations.

2.3 Specific effects

2.3.1 Effects on residents

Effects on residents generally involve a perceived reduction of amenity arising from light technical factors such as the following:

- (a) The illumination from spill light being obtrusive, particularly where the light enters habitable rooms. The illuminance on surfaces, particularly vertical surfaces, is an indicator of this effect.

- (b) The direct view of bright luminaires from normal viewing directions causing annoyance, distraction or even discomfort or disability glare. The luminous intensity of a luminaire, in a nominated direction, is an indicator of this effect.
- (c) Changes in luminance in the peripheral vision due to effects such as variable content in signage or trees moving across bright lights.

The tolerable levels of each of these light technical parameters will be influenced by the ambient lighting existing in the environment where the light technical parameters are being calculated.

There is some evidence that exposure to artificial light at night may have adverse impacts on human health. However, caution is needed in interpreting the specific influence of outdoor lighting on human health. The effects of outdoor lighting on human health are beyond the scope of this document, noting that conformity to this document will limit exposure of humans to outdoor lighting.

2.3.2 Effects on transport system users

One of the effects on transport system users (e.g. pilots, water craft operators, train drivers, motorists, cyclists) normally involves a reduction in the ability to see caused by disability glare from bright light sources. The contrast of other objects and the surrounds to the user will be lowered, rendering them less visible or even invisible, especially if the environment is intrinsically dark. The magnitude of the effect will depend on the level of lighting to which the user is adapted. The relevant indicator for transport system users is the threshold increment (*TI*).

2.3.3 Effects on transport signalling systems

Effects on transport signalling systems will normally involve a reduction in the visibility of the signals either by—

- (a) disability glare; or
- (b) visual clutter; where signals are viewed against a competing background of other lighting. The effect is exacerbated if background lighting is the same colour as the signal lighting or a mix of colours.

2.3.4 Effects on the night sky (sky glow)

Sky glow is a combination of man-made sky glow and natural sky glow, this document only addresses man-made sky glow.

Sky glow is the cumulative effect of each and every light source in a development, and hence its minimization is achieved by careful selection, placement and screening of all light sources.

The increase in man-made sky glow can have a wide range of detrimental effects.

NOTE Refer to CIE 126–1997 for guidance on minimizing sky glow.

2.3.4.1 Astronomy

Visibility of the night sky is important for astronomical observations both for science and for the general appreciation of the night sky.

Effects on astronomical observations will generally involve the modification of night sky viewing conditions by any or all of the following:

- (a) Lightening of the dark sky caused by the scattering of light from the installation, in the atmosphere, increasing sky glow.
- (b) The spectral characteristics of the sky glow, so that the light pollution is not readily filtered out by optical means at the telescope.

(c) Direct light from the installation falling on the observatory.

Where outdoor lighting systems are proposed in the vicinity of community or scientific optical observatories the limitations of spill light and luminous intensity of luminaires in recommended directions will mitigate the adverse effects of direct light falling on the optical surfaces of the telescope.

Sky glow may be mitigated by limiting the exterior lighting in the vicinity of the observatory, including the spectral distribution and optical distribution of the local road lighting. If this measure is to be implemented, close consultation will be needed between all the parties involved, i.e. observatory, local community and relevant authority.

NOTE A list of community and scientific optical observatories is available from the Astronomical Society of Australia (Designated Observatories Officer), c/o School of Physics, University of Sydney, NSW 2006 and the Royal Astronomical Society of New Zealand (rasnz.org.nz).

Where the proposed lighting is within the field of influence of a major optical observatory, the above points are even more pertinent. Additional limitations on spill light may be imposed over a considerable area surrounding the observatory as part of a long-term plan to maintain satisfactory night sky viewing conditions. Such plans should be based on guidelines set out by the International Commission on Illumination and the International Astronomical Union in CIE 001-1980.

2.3.4.2 Cultural impacts

Cultures around the world, including many First Nations traditions and knowledge systems, are based on the stars and other celestial objects, and the peoples' ability to observe and interpret the night sky.

The mitigation for the preservation of culture is similar to the controls for astronomy.

2.3.4.3 Impact on flora and fauna

The impact on flora and fauna is addressed more generally in [Clause 1.1](#). However, the increase in sky glow can have an overall impact on the navigation and feeding of fauna which can have consequential impacts on the overall environment. The skyglow impacts on flora and fauna can be caused by light emitted at a lower altitude and be localized to specific installations.

2.3.4.4 Impact of the spectral content of the light

The blue content of the light has an impact on the sky glow as it scatters more in the atmosphere than light at the red end of the spectrum.

Preference should be given to sources with a correlated colour temperature of 3 000 K or less unless there is a safety reason for using 4 000 K. For CCT in public lighting refer to SA/SNZ TS 1158.6.

While Spectral Power Distribution (SPD) provides a better indication of the blue content in the light source there are no criteria to specify a limit that can be applied. Sources with low blue content are preferred.

Removal of the blue content of light, while effective in reducing the impact on astronomy and the overall brightness of the sky, is not a universal solution. Care should be taken in general limitation of blue light as there are some animals that prefer blue light, and as the illumination levels reduce, human vision moves into the scotopic zone which primarily relies on blue light for visual performance.

NOTE Sports fields have high levels of human activity, task visibility is challenging, and they are often used during sunset. Sources of up to 5 700 K ("daylight") can satisfy end user preferences, and when combined with the principles described in [Clause A.2](#) by a competent lighting designer, other adverse effects can be substantially mitigated, e.g. sky glow/ULR, glare, and spill light.

2.3.5 Effects on the natural environment

Effects on the natural environment may include behavioural changes in animals, physiological changes in plants and animals and changes in the interactions between organisms. Light can affect all living species (including plants, animals and other organisms) in all habitat types (land, air and water).

These changes can occur at very low light levels, for example some species change their behaviour with the waxing and waning of the moon. The physiological responses of some species may also be affected by the spectral composition of the light, particularly at short wavelengths.

NOTE The most effective way to avoid impacts on environmentally sensitive areas is to minimize spill light and upward light. See [Appendix C](#) for further information on the impact of outdoor lighting on the flora and fauna.

Section 3 Light technical parameters

3.1 General

This section specifies the limits for the relevant Light Technical Parameters (LTPs), their assessment and where they are to be applied.

For the purpose of applying the LTPs a lighting system shall be counted as a stand-alone installation. Where there are lighting installations on several properties their impact may be assessed independently of each other.

Where the lighting installation site contains existing lighting, the vertical illuminance from the existing lighting installation should be allowed for in the assessment. The allowance may be based on site measurements, design simulations, or the application of a lower maximum illuminance limit.

Planned increases to a lighting installation, both proposed or existing, e.g. increased lighting levels, or additional areas, should be included in the assessment.

Where the lighting system is within an affected property which contains multiple dwellings, any relevant existing sports lighting within the affected property shall be included in the assessment. Where required by the relevant authority, the impact of public lighting shall be assessed independently of other lighting impacts (see [Section 4](#)).

Based on the zoning of the sites adjacent to the lighting system and any environmentally sensitive areas it may be necessary to consult appropriate persons with competence in the fields of illuminating engineering and environmental assessment to determine the potential effects of a specific proposal.

3.2 Limits for light technical parameters

3.2.1 Applicable limits

The indicators of potential obtrusive effects identified in [Clause 2.3](#) relate to the initial light technical parameters specified in [Tables 3.2](#) to [3.4](#). These limits are applicable to residents, transport system users, environmentally sensitive areas, and astronomical observatories. Although these limiting values are intended to control the obtrusive effects, they will not necessarily ensure that a conforming installation will receive no adverse reaction from those affected by the spill light.

This is particularly true for environmentally sensitive areas as no limits have been identified that will ensure no adverse effects; however, limiting light spill into environmentally sensitive areas and minimizing sky glow will have environmental benefits.

Conformance with this document will not necessarily meet the requirements of environmental legislation, and the effect on areas with protected species or ecological communities is out of scope of this document, see [Appendix C](#). Conformance to the limiting values indicates that good practice control measures have been utilized.

Different limits have been applied based on the ambient light conditions. These ambient conditions are described for each of the environmental zones in [Table 3.1](#).

Two sets of limits are specified in [Tables 3.2](#) and [3.3](#) for the parameters E_v (vertical illuminance) and I (luminous intensity) respectively based on the times that the lighting system is to operate. A higher level of lighting may be less obtrusive in the early hours of the evening when there is more activity, and the majority of people are awake. For later times (in the curfew period) lower limits have been applied. For environmentally sensitive areas, a curfew may provide some respite from obtrusive light spill, though this may not mitigate problems due to changes in the duration of daylight hours.

Unless otherwise specified by the relevant authority, the times for determining which set of limits applies, i.e. curfew period, should be taken as being between 11 p.m. and 6 a.m.

The lower limit for application during the curfew period need not apply where it can be demonstrated to the satisfaction of the relevant authority that there will be no adverse effects on residents or wildlife e.g. no nearby residential development, either existing or planned. Where the affected property is or includes an environmentally sensitive area, the lower limit shall apply at all times. Where a different curfew period applies for other reasons (e.g. noise control), consideration should be given to the coordination of the curfews, e.g. allowing sufficient time of operation for the lighting after the conclusion of the activity to facilitate crowd dispersal.

3.2.2 Applicable light technical parameters

All calculations shall use a maintenance factor of 1.0.

Where controls, such as dimming or shields, are required for conformance, then details shall be detailed in the certification.

The following light technical parameters shall apply:

(a) Vertical illuminance (E_v)

The vertical illuminance shall be calculated in accordance with [Clauses 3.3.1.3](#) to [3.3.1.6](#).

(b) Luminous intensity (I)

The luminous intensity shall be assessed for all systems other than lit surfaces in accordance with [Clause 3.2.5](#). Level 1 limits shall be used for all new systems. Level 2 limits can only be applied to the specific luminaires identified in accordance with [Clause 3.2.5](#) (e).

(c) Average luminance

The average luminance shall be assessed for internal and external illuminated signs, façades and artworks. If an internally illuminated surface is less than 0.4 m², and is not adjacent to other similar surface, then it should be treated as a luminaire and shall conform to the luminous intensity limits of [Table 3.3](#) rather than luminance.

(d) Threshold increment (TI)

The TI on transport corridors affected by the lighting system shall conform to the limits in [Table 3.2](#) and calculated in accordance with [Clause 3.3.1.7](#) and [Clause 3.3.3.3](#).

(a) Upward light ratio (ULR_S and ULR_L)

The upward light ratio for all lighting systems other than those systems exempted in [Clause 1.1](#) shall conform to the limits in [Table 3.2](#) and [Clause 3.3.3.4](#) as applicable, and calculated in accordance with [Clause 3.3.1.8](#).

3.2.3 Basis for differentiation of limits according to area type

The limiting values specified for E_v , I , TI , ULR_S and ULR_L in [Tables 3.2](#) to [3.4](#) are differentiated according to the environment type (see [Table 3.1](#)). The differentiation takes account of land use zoning which, in part, reflects the function of the lighting, and the existing and future level of night-time activity to be expected in the area.

Table 3.1 — Environmental zones

Environmental zones	Ambient light conditions	Descriptions/ Examples
A0	Intrinsically dark	UNESCO Starlight Reserve. IDA: Dark Sky Parks, Reserves or Sanctuaries Major optical observatories Other accreditations for dark sky places for example astrotourism, heritage value, astronomical importance, wildlife/ecosystem protection Lighting for safe access may be required
A1	Dark	Relatively uninhabited rural areas (including terrestrial, marine, aquatic and coastal areas) Generally roadways without streetlighting through rural areas
A2	Low district brightness	Sparsely inhabited rural and semi-rural areas Generally roadways without streetlighting through suburban, rural or semi-rural areas other than intersections
A3	Medium district brightness	Suburban areas in towns and cities Generally roadways with streetlighting through suburban, rural or semi-rural areas
A4	High district brightness	Town and city centres and other commercial areas Residential areas abutting commercial areas Industrial and Port areas Transport Interchanges
TV	High district brightness	Vicinity of major sport and event stadiums during TV broadcasts
NOTE Zones A0 and A1 would normally have a minimum area of 50 ha.(0.5 km ²). There may be smaller environmentally sensitive areas.		

3.2.4 Basis for differentiation of limits for E_v and I according to times of operation

There is a potential conflict between the lighting requirements necessary to facilitate an activity and the maintenance of amenity and environmental integrity. Two sets of limits for E_v and I are given, based on the times that the lighting is to operate, as follows:

- (a) *Limits for non-curfew period* The higher of the two sets of limits shall apply for operation of the lighting outside the curfew.

The non-curfew limits have as their objective the facilitation of the intended activity while giving recipients of spill light some relief from it being obtrusive.

- (b) *Limits for curfew period* The lower of the two sets of limits shall apply for operation of the lighting during the curfew period during which maintenance of the amenity and environmental integrity of the area become the dominant considerations.

3.2.5 Basis for differentiation of limits for luminous intensity (I) according to precedent

Level 1 (L1) and Level 2 (L2) limits for intensity (I) shall be in accordance with [Table 3.3](#).

Generally, L1 limits shall be used unless there are certain circumstances that justify L2 limits, specifically—

- (a) where there is no existing lighting system, and new luminaires are used on new support structures, e.g. poles, buildings, grandstands, L1 limits shall apply;

- (b) where there is no existing lighting system, and new luminaires are used on existing support structures, L1 limits shall apply;
- (c) where there is an existing lighting system that is being removed/replaced, and where new luminaires are used on new support structures L1 limits shall apply
- (d) where there is an existing lighting system that is being retained, either wholly, or in part, any new luminaires on new support structures shall meet L1 limits; and
- (e) where there is an existing lighting system that is being retained, either wholly, or in part, or is being removed/replaced, any new luminaires on existing support structures should meet L1 limits. Where the existing support structures are not sufficiently high, or in ideal locations, such that the necessary LTP's for the primary purpose of the lighting system cannot be reasonably achieved, then L2 limits may be used for new luminaires. The application of L2 limits should be strictly limited to only those luminaires where L1 cannot be reasonably achieved, and not generally applied to the whole system. Where L2 limits are used it should be demonstrated that the obtrusive effect of the new scheme is not greater than the previous lighting system.

3.3 Assessment of conformance

3.3.1 Environmental Zones A0-A4

3.3.1.1 General

Conformance to the limiting values specified in [Tables 3.2](#) to [3.4](#) shall be assessed on the basis of calculations of the applicable light technical parameters.

NOTE See [Appendix E](#) for guidelines on conducting check measurements.

3.3.1.2 Application of environmental zones

The environmental zone used for assessment shall be selected based on the ambient light conditions and descriptions included in [Table 3.1](#) and any relevant authority requirements. The applicable environmental zone for a lighting system or affected property shall be based on the current zoning for future development of the area irrespective of the level of current development. Provisions can be made at the time of design to allow for future zone changes; however, the installation cannot be operated at a higher level until the zone has been formally changed.

For vertical illuminance and luminous intensity the environmental zone shall be selected for the lighting system and/or for each affected property and in accordance with the following:

For vertical illuminance and luminous intensity:

- (a) An abutting affected property shall be assessed as the same environmental zone as the lighting system unless the abutting affected property is an environmentally sensitive area, recreational areas, an off-road carpark, or the lighting system is used for sports.
- (b) The affected property past the abutting affected property outlined in (a), shall be assessed as the environmental zone applicable to that property irrespective of the environmental zones of the adjacent affected properties, e.g. if the lighting system is a petrol station that is in an A4 zone, the adjacent affected property will be assessed as A4 and if the affected property past the abutting property is A3 it will be assessed as A3.
- (c) Where the abutting affected property is an environmentally sensitive area it shall be assessed as the environmental zone applicable to that property irrespective of the environmental zones of the adjacent properties, or the lighting system.

- (d) For sports, recreational area, and off-road car park lighting systems, the abutting affected property shall be assessed as the environmental zone applicable to that affected property irrespective of the environmental zone of the lighting systems.
- (e) For sparsely inhabited rural and semi-rural areas (Zone A2) that are adjacent to a sports field illuminated to an average of 100 lx or more, as per AS 2560, Zone A3 limits may be applied where acceptable to the relevant authority

For luminance of lit vertical surfaces, the environmental zone shall be selected for the lighting system and/or for each affected property and in accordance with the following:

- (i) The luminance shall be assessed based on the environmental zone of the lighting system.
- (ii) Where internally illuminated signs are proposed to be installed abutting a environmentally sensitive area, the environmental zone for the assessment shall be the zone of the site that the sign is located; however an assessment of the specific nature of the sensitive area shall be made to address the specific impact on any endangered flora and fauna in the specific area affected by the sign.

3.3.1.3 Calculation of illuminance (E_v) and intensity (I) in a vertical plane

Demonstration of conformance to the limits specified in [Tables 3.2](#) to [3.4](#) requires a detailed analysis of the situation with the identification of potential problem locations, e.g. windows of dwellings and specific viewing directions of concern.

Limiting values are for the direct component of luminous flux only. Reflected light shall not be included. Refer to [Clause 3.3.1.6](#) for obstructions.

The maximum intensity from any luminaire in the lighting system, and the maximum vertical illuminance shall be calculated at either of the following point/s:

- (a) For an affected property where there is an existing dwelling, calculations shall be at the centre of the windows of habitable rooms with views of the lighting system. For windows with a width or height of 2 m or more, a grid of points shall be used with a maximum spacing of 2 m in either direction. Alternatively, calculations may be as stated in [Clause 3.3.1.3](#) (b).
- (b) For an affected property with no dwelling (including environmentally sensitive areas) calculations shall be at a grid of points on relevant vertical plane/s as described in [Clause 3.3.1.4](#) and [3.3.1.5](#). The points shall be spaced at not more than 2 m horizontally, and 1 m vertically, unless the luminaire(s) are greater than 20 m from the nearest calculation point; then the points may be spaced at not more than 5 m horizontally, and 2 m vertically.

3.3.1.4 Vertical calculation plane location

The calculation plane location shall be determined as follows, see [Figure 3.1](#):

- (a) Where there is an existing dwelling the location of the calculation plane is generally determined at the building line of the potentially affected dwelling/s. The building line is the face of an existing dwelling that contains windows of habitable rooms but does not include balconies and verandahs.
 - (i) Where a building line is less than 10 m from a relevant boundary the calculation plane/s shall be at the building line. Should the building line extend greater than 10 m from the closest relevant boundary, the calculation plane shall be deviated at that point to a non-relevant boundary, or to within 10 m of a relevant boundary. The deviated calculation plane shall be parallel to the closest relevant boundary. See [Figure 3.1](#) a) c) and e).
 - (ii) Where a building line is greater than 10 m from the relevant boundary the calculation plane/s shall lie along a line that is no greater than a 10 m zone from

all relevant boundaries and extending to non-relevant boundaries. See generally [Figure 3.1](#) b), and also a) and e).

- (b) For lots with no dwelling boundaries, i.e. a vacant lot, the calculation plane shall lie along a line at a distance from all relevant boundaries that is no greater than minimum setback required by the relevant authority for the construction of a new dwelling. If the setback has not been determined, is unknown, or is greater than 10 metres, then a 10 m setback distance shall be assumed. See [Figure 3.1](#) d).
- (c) For environmentally sensitive areas the location of the calculation plane is generally determined at a distance inside of the relevant boundary.
 - (i) For A0, A1 or A2 environmentally sensitive areas the calculation plane/s shall lie along a line that is no greater than a 10 m from all relevant boundaries, and extending to non-relevant boundaries. Where an internally illuminated sign is located in an A2 area, the calculation plane/s shall lie along a line that is no greater than a 20 m buffer zone from all relevant boundaries and extending to non-relevant boundaries. See [Figure 3.1](#) f).
 - (ii) For A3 or A4 environmentally sensitive areas, the buffer zone can be up to 50 m, provided that the width of the buffer zone is less than 10 % of the overall depth of the environmentally sensitive area as measured inwards from the relevant boundary. See [Figure 3.1](#) f).

Where an existing building line, or future dwelling is greater than 10 m from a relevant boundary, the provision of a 10 m limit protects them from being subject to excessive light beyond the first 10 m. For large lots where existing or future dwellings are significantly distant from the relevant boundaries, the 10 m limit may be increased in agreement with the relevant authority.

Where there are numerous calculation planes, they may be combined into a simplified calculation plane/s for more convenient analysis. Such simplified calculation plane/s shall be located closer than strictly necessary to the subject luminaires such that higher values will be reported.

Where the calculation plane is not at a relevant boundary, the results at the relevant boundary may be used for conformance assessment such that higher values will be reported, e.g. at a residential property boundary instead of a building line. This will generally demonstrate a superior level of control.

Where the calculation plane is not at a relevant boundary, the results at the relevant boundary may additionally be calculated to permit comparison with site measurements.

If conformance is not achieved at the required calculation plane location the installation shall be reported as non-conforming. The setback distance at which the limits are achieved may be determined and used to guide modification of the installation to achieve compliance or the significance of the non-conformance.

NOTE The figures (a) to (f) in [Figure 3.1](#) do not correspond with subclauses (a) to (f) of this clause.

3.3.1.5 Height of the vertical calculation points

The height of the points in the vertical plane shall be as follows, see [Figure 3.2](#):

- (a) Where the calculation plane is along a building line of an existing building, the highest calculation points shall be taken to be the top of the highest window of the habitable rooms. The lowest calculation points shall be taken to be the bottom of the lowest window of the habitable rooms.
- (b) Where the calculation plane is along a boundary with a minimum dwelling or other setback, the highest calculation points shall be taken to be the maximum building height permitted by the land use zoning provisions. The lowest calculation point shall be 1.5 m or less above ground level. Where there is no maximum building height in the zoning the highest calculation point shall be equal to the height of the highest luminaire subject to analysis.

- (c) Where the calculation plane is along a residential property boundary the lowest calculation points shall be 1.5 m above ground level, and the highest calculation points shall be determined either by—
- (i) the intersection of the 'lines of sight' between the luminaires subject to analysis and the highest points that might occur on the building line, or setback calculation planes, and the vertical plane at the property boundary; or
 - (ii) the height of the highest luminaire subject to analysis.
- (d) Where the calculation plane is along a boundary of an environmentally sensitive area —
- (i) if the lighting system has an ULRS less than or equal to 0.01 then the top of the calculation plane shall be equal to the height of the highest luminaire or 10 m, whichever is greater;
 - (ii) If the lighting system has a ULRS greater than 0.01 then the top of the calculation plane shall be twice the height of the highest luminaire or 30 m, whichever is greater; and
 - (iii) where the luminaire has a relatively large size, e.g. is a sign or façade, etc. then the height of the luminaire shall be taken as the top of the luminous opening.

3.3.1.6 Obstructions

Where there is a permanent obstruction between the light source and the calculation points, the vertical illuminance or intensity need not be calculated for points within the area of the calculation plane that are obstructed. An obstruction can be considered opaque if the following criteria apply:

- (a) There shall be consistent light transmission throughout the year.
- (b) There shall be a light transmission factor of less than 0.2.
- (c) No image of the light source shall be visible through the obstruction.

If the obstruction is translucent with a transmission factor greater than or equal to 0.2 then the vertical illuminance shall be calculated, ignoring the impact of the obstruction, and multiplied by the transmission factor of the obstruction.

If the obstruction is transparent, such that there is a visible image of the luminaire, then the luminous intensity shall be multiplied by the transmission factor.

If the obstruction is diffuse, such that the image of the luminaire is obscured, then the luminous intensity shall be calculated by calculating the illuminance on the face of the obstruction, multiplying it by the transmittance, divided by π and multiplied by the projected area of the lit section of the obstruction.

Trees and foliage may be considered as obstructions provided that —

- (i) they are evergreen;
- (ii) the obstruction comprises one or more tree or plant that achieves a transmission factor of 0.2;
- (iii) the light sources are not visible through the tree or plant; or
- (iv) the trees and plants are sufficiently developed at the initial operation of the lighting to achieve the level of obstruction assumed in the conformance certification.

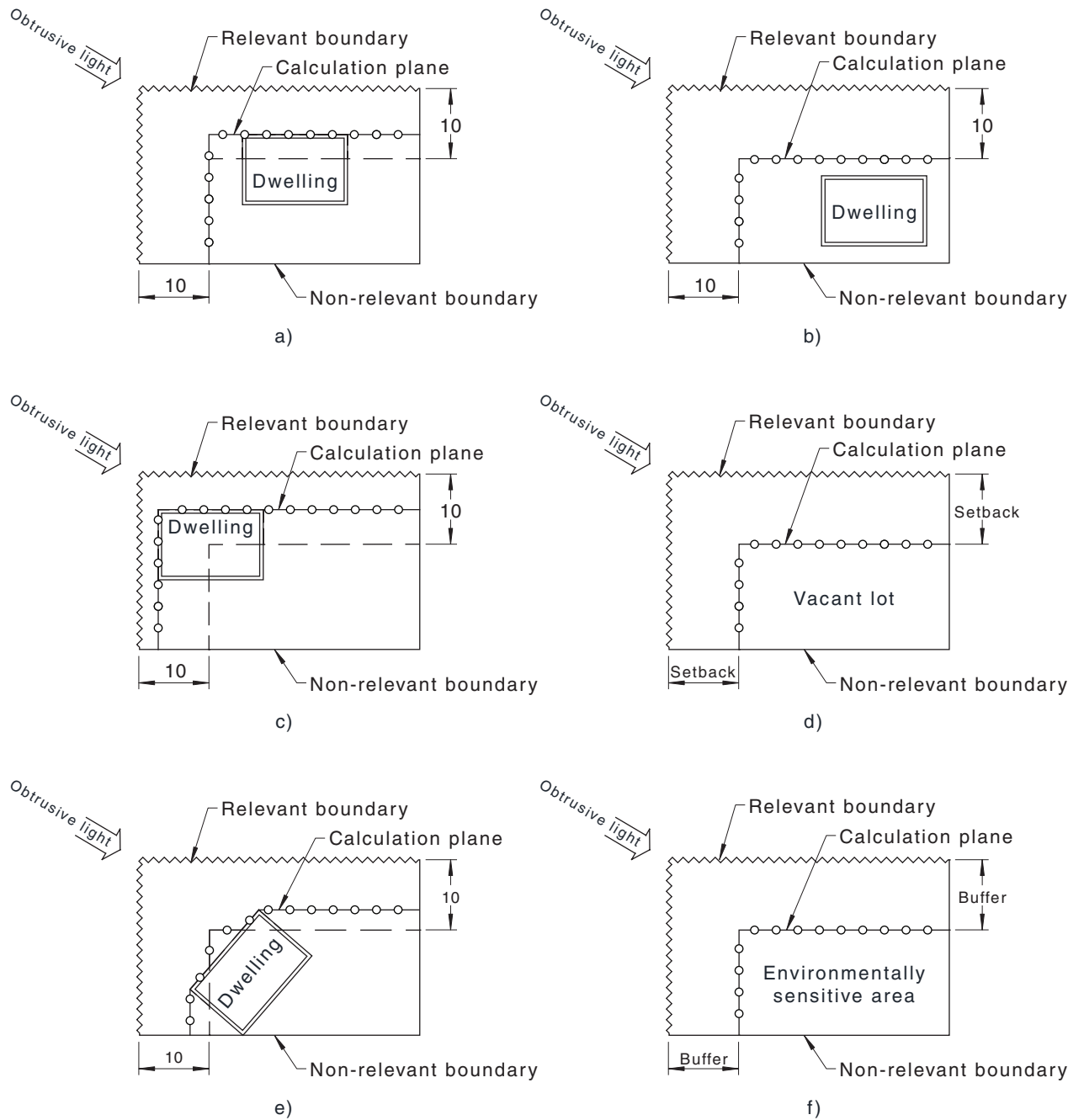

Figure 3.1 — Examples showing application of limits for E_V and I for zones A0 to A4

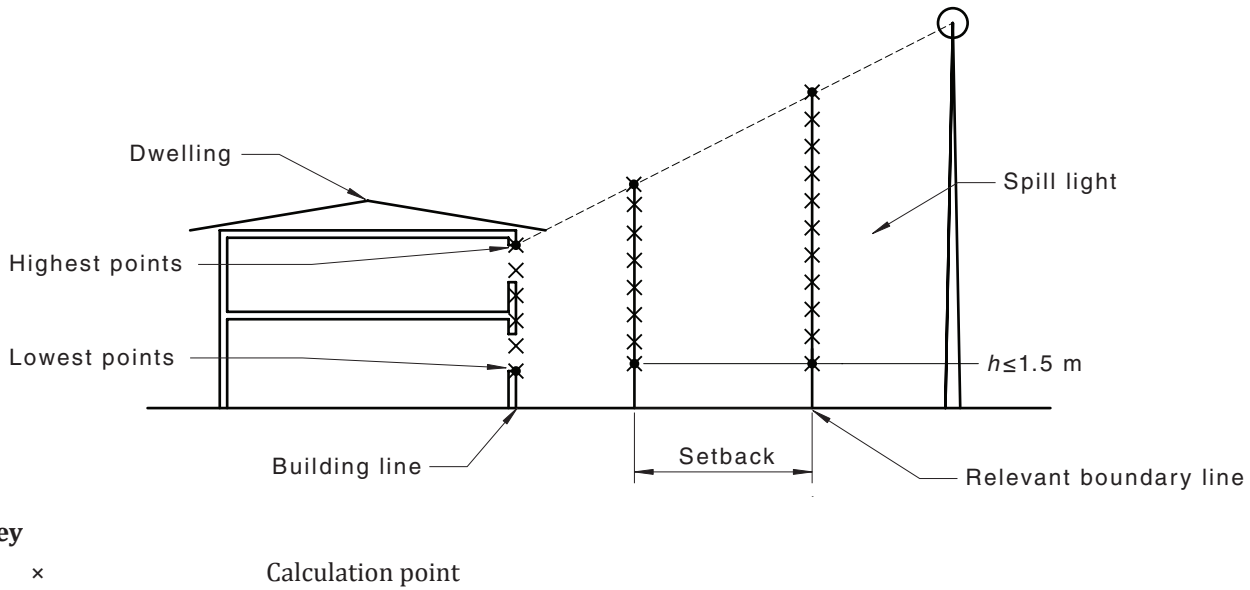

Figure 3.2 — Example of location and height of calculation points for limits for E_V and I for zones A0 to A4 (excluding environmentally sensitive areas)

3.3.1.7 Calculation conditions for threshold increment (TI)

The threshold increment, TI , shall be calculated as follows:

$$TI = 65L_v / (L_{ad})^{0.8} \quad 3.1$$

where

L_v = veiling luminance, in candelas per square metre (cd/m^2), see [Equation 3.2](#)

L_{ad} = adaptation luminance, in cd/m^2

= \bar{L} (average luminance for a transport corridor)

\bar{L} may be calculated on the relevant transport corridor (e.g. carriageway) for the specific site conditions. \bar{L} is as defined in AS 1158.1. For other situations the values of adaptation level (L_{ad}) in [Table 3.2](#) may be assumed.

Only luminaires that lie within the range 1.5° and 60° from the observer's line of sight, in any direction, shall be taken into account in the calculation of TI .

The driver's eye height shall be 1.5 m above the road surface.

The driver's line of sight shall be parallel with the centre-line of the road and 1° down relative to the plane of the road surface.

The cut-off angle of the windshield (windscreen) should be assumed to be 20° above horizontal.

Only direct light shall be considered in the TI calculations (no inter-reflected light, even if calculated with the full radiosity method).

For the purpose of assessing TI , the ground plane shall be assumed to be horizontal.

The veiling luminance, L_v from [Equation 3.1](#) shall be calculated as follows:

$$L_v = 10 \Sigma \left(\frac{E}{\theta^2} \right) \quad 3.2$$

where

- E = the initial illuminance at the observer's eye from one luminaire, in lux
- θ = the eccentricity of the luminaire from the observer's line of sight, in degrees
- Σ indicates that the contributions from all luminaires are summed

3.3.1.8 Upward light ratio

3.3.1.8.1 General

The upward light ratio is a measure of the extent to which the system directly contributes to the sky glow. The definitions of upward light ratio are different to that in the AS/NZS 1158 series of standards as the application in this document is wider.

This document allows alternative methods of assessing upward light. The limit in [Table 3.2](#) shall apply to the whole installation, see [Clause 3.3.1.8.2](#). Therefore, individual luminaires are permitted to exceed the value provided the installation meets the limit in [Table 3.2](#). A superior level of control can be demonstrated when all individual luminaires conform, see [3.3.1.8.3](#).

3.3.1.8.2 Upward light ratio (system) ULR_S

The whole system can be evaluated for the design position(s) of the luminaire(s) using the following equation:

$$ULR_S = \Sigma \phi_A / \Sigma \phi_T \quad 3.3$$

where

- $\Sigma \phi_A$ = the total flux emitted by all the luminaires above the horizontal at the aiming angle, in lumens (lm) excluding light that is incident on surfaces e.g. the ground, objects or obstructions.
- $\Sigma \phi_T$ = the total flux emitted by all the luminaires, in lumens (lm)

If the system can be shown to conform without modelling of all the obstructions, then there is no requirement to model all the obstructions.

3.3.1.8.3 Upward light ratio (luminaires) ULR_L

Where louvres or shields, within or external to the luminaire, are used the impact of these louvres and shields can be included in the ULR_L calculations.

The upward light ratio (luminaires) can be used to assess the direct spill light to the sky from a specific luminaire. The luminaire shall be evaluated for the design position(s) of the luminaire(s) using the following equation:

$$ULR_L = \phi_A / \phi_T \quad 3.4$$

where

ϕ_A = flux emitted by the luminaire above the horizontal at the aiming angle, in lumens (lm)

ϕ_T = total flux emitted by the luminaire, in lumens (lm)

If all the luminaires in the lighting system individually meet the ULR limit in [Table 3.2](#) then the lighting system conforms.

3.3.2 Sport and event venues illuminated for TV coverage

3.3.2.1 General

Conformance to the TV zone limiting values specified in [Tables 3.2](#) and [3.3](#) shall be assessed while the broadcast lighting system is in operation, at maximum operating level. When the venue is used for purposes not requiring a high level of illuminance as for TV broadcasting, e.g. a lower level of competition, or training, then it shall be assessed in accordance with Environmental Zones A0-A4 limits per [Clause 3.3.1](#).

Conformance to the limiting values indicates that good practice control measures have been used, but it does not necessarily mean that the obtrusive effects will receive no adverse comments and not that the obtrusive effects will be devoid of impacts to all receivers. Residences in the vicinity of such venues will be subject to obtrusive effects while the televised sports TV lighting system is in operation.

Where the sports TV lighting system is for a venue that is not a typical stadium type, e.g. horse racing tracks (flat/gallop, and harness), greyhound racing tracks, motor racing tracks, golf courses, etc., or it is intended to be used on a relatively high number of occasions, or where the relevant boundary is relatively close to the illuminated sports area, it is recommended that the maximum vertical illuminance (E_v) be assessed in accordance with [Clause 3.3.1](#), and the limits for E_v should be 12 % of the initial (MF = 1) average illuminance to the camera over the Principal Playing Area (PPA, refer to AS 2560.1), or the illuminated section in the vicinity of the relevant boundary. Where such an assessment is deemed necessary, it should be undertaken by persons who are professionally qualified and competent in the discipline of illuminating engineering with experience with sports lighting systems for television and with the relevant authority.

3.3.2.2 Calculation of intensity (I)

The intensity limits in [Table 3.3](#) shall apply to each luminaire at all azimuth planes for all elevation angles at and above the control direction when the luminaire is mounted in its design position.

The control direction is 7° below the horizontal, see [Figure 3.3](#). See [Clause 3.2.5](#) for the basis of application of level 1 and level 2 limits.

Where it can be established that a luminaire is not visible from relevant boundaries outside of the property being lit, then intensity limits do not apply to that luminaire, see [Clause 3.3.1.6](#)

Where a luminaire does not conform with Level 1 control direction limits, conformance may be demonstrated by having a maximum intensity of not more than 165 000 cd assessed in the direction of the windows of habitable rooms in accordance with [Clause 3.3.1.3](#),

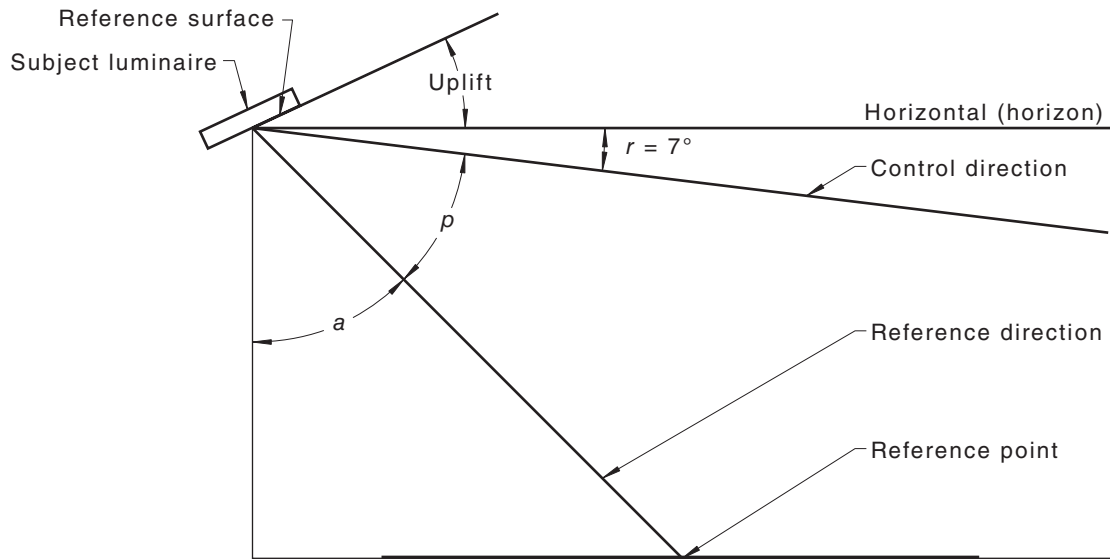

Key

a = reference angle of the subject luminaire photometry, in elevation

ρ = angular displacement, in elevation, of the control direction from the reference direction

r = angular displacement between the control direction and the horizontal

Figure 3.3 — Illustration of the various reference angles for determining intensity limits for TV broadcasting

3.3.3 Lit surfaces

3.3.3.1 General

This clause covers surfaces that may produce obtrusive light either by emitted or reflected light and includes internally and externally illuminated signs, façade lighting and objects. The LTPs for these surfaces shall be no greater than the applicable limits in [Tables 3.2](#) and [3.4](#).

An internally illuminated sign may include digital signs with exposed or lensed LEDs, backlit signs and similar light emitting signage.

Where an internally illuminated sign or object operates during non-curfew operation only, the LTPs do not apply if the total illuminated area is less than or equal to 0.25m^2 . Where the sign or object comprises a series of modules, the illuminated area shall be the sum of all modules.

During curfewed operation, the LTPs do not apply into internally illuminated signs or objects with an illuminated area less than or equal to 0.05m^2 .

Luminous intensity limits are not applicable unless there is direct view of the light emitting surface of a luminaire or there is a specular reflection in the surface being lit.

3.3.3.2 Signs, façades and artwork with dynamic content

Where a sign, façade or artwork displays dynamic content and is located within 100 m of the relevant boundary of a residential dwelling with views to the content, the resulting vertical illuminance (E_v) limit shall be not greater than 50 % of the maximum allowable in [Table 3.2](#),

3.3.3.3 Calculation procedures

3.3.3.3.1 Internally lit and light emitting surfaces

The maximum average luminance of the sign, façade, or artwork shall be not greater than the limits in [Table 3.4](#). Signs that can be seen by drivers shall have the threshold increment calculated. The TI shall be not greater than the limits in [Table 3.2](#).

The average luminance shall be based on a full white image at the night level unless the following apply:

- (a) Where a surface has fixed colours the average luminance may be calculated for those colours.
- (b) Where the whole surface does not emit light, the surface area used in the calculation shall only include that area where the luminance is greater than 10 % of the maximum luminance.
- (c) Where the light emitting surface is diffuse, the luminous intensity for the purpose of calculating the vertical illuminance (E_v) may be the average luminance multiplied by the projected area of the lit surface. Where the light emitting elements of the lit surface have a directional characteristic with a beam angle of less than 90° then the actual luminous intensity of the lighting elements shall be used.
- (d) Where the distance from the surface to the calculation plane is less than 5 times the maximum dimension of the surface, the surface shall be subdivided into smaller elements such that the maximum dimension of the smaller elements is < 20 % of the distance between the surface and calculation plane. Vertical illuminance is determined for each smaller element and summed.

The vertical illuminance (E_v) shall be calculated in accordance with [Clause 3.3.1.3](#).

3.3.3.3.2 Externally illuminated surfaces

The maximum average luminance of the signs, façades or artworks shall be not greater than the limits in [Table 3.4](#).

The average luminance shall be based on the surface reflectance as follows:

- (a) The average luminance shall be calculated by multiplying the average illuminance by the average reflectance of the surface divided by π . The area of the calculation for the illuminance shall be the area illuminated to greater than 10 % of the maximum illuminance. Where the reflectivity of the surface can be changed the calculation shall be based on a white surface with a reflectance of 80 %.
- (b) Where the illuminated surface has a high level of specularity so that the image of the light source can be seen in the surface, the luminance shall be taken as the luminance of the light source multiplied by the specular reflectance of the surface.
- (c) The luminous intensity of the surface for the purpose of calculating the vertical illuminance can be the average luminance multiplied by the projected area of the surface.

Where there is direct vision of the light source or the flashed area of the reflector then the luminous intensity limits of [Table 3.3](#) shall apply.

- (d) Where the distance from the surface to the calculation plane is less than 5 times the maximum linear dimension of the surface, the surface shall be subdivided into smaller elements.
- (e) The vertical illuminance (E_v) shall be calculated at the window of the habitable dwelling in accordance with [Clause 3.3.1.3](#).

NOTE Despite the exemption for the facades of classified heritage buildings and objects the designer should, where practical, design to minimize the upward light component.

3.3.3.4 Control of upward waste light

The upward light impact of lighting included under [Clause 3.3.3](#) shall be assessed as individual items as follows:

- (a) Internally illuminated signs and other internally illuminated objects shall have a ULR_L of ≤ 0.50 .
- (b) Digital signs shall have a ULR_L of ≤ 0.45 .
- (c) Externally lit signs and billboards shall be lit from the top and shall have a ULR_L or ULR_S no greater than that specified in [Table 3.2](#).

For other lit surfaces not included in (a) to (c), e.g. façade lighting, walls, and trees, the lighting system shall include measures which mitigate upward waste light. See [Appendix A](#) for guidance.

3.3.3.5 Lighting of flags and banners

Flags and banners, that are not exempt, if required to be lit, should be lit from ambient light from other sources or luminaires mounted above the top of the flag or banner and shall have a ULR of less than 0.4. The luminaires shall still meet the other LTPs in this document.

See [Appendix D](#).

Table 3.2 — Light technical parameter limits

Zones	Maximum vertical illuminance (E_v) lux		Threshold increment (TI)		Upward Light Ratio
	Non-curfew	Curfew	Maximum TI %	Default Adaptation level (L_{ad}) cd/m^2	Maximum ULR_S or ULR_L
A0	0 ^a	0.0	N/A	N/A	0.00
A1	2	0.1	20	0.1	0.00
A2	5	1	20	0.2 ^b	0.01
A3	10	2	20	1	0.02
A4	25	5	20	5	0.03
TV	N/A	N/A	20	10	0.08

^a For A0, E_v shall be as close to zero as practicable without impacting safety considerations.

^b For an internally illuminated sign in a A2 zone, $L_{ad} \leq 0.25 \text{ cd/m}^2$

Table 3.3 — Maximum luminous intensities per luminaire

Zone	Luminous intensity (<i>I</i>), cd		
	Non-curfew Level 1 (L1)	Non-curfew Level 2 (L2)	Curfew
A0	See Note	See Note	0
A1	2 500	5 000	500
A2	7 500	12 500	1 000
A3	12 500	25 000	2 500
A4	25 000	50 000	2 500
TV	100 000	165 000	0

NOTE For A0, *I* shall be as close to zero as practicable without impacting safety considerations.

Table 3.4 — Maximum average luminance of surfaces (cd/m²)

Application conditions	Environmental zones				
	A0	A1	A2	A3	A4
See Clause 3.3.3	0.1	50	150	250	350

Section 4 Public lighting

4.1 General

When the relevant authority deems it necessary to limit the obtrusive light from a public lighting installation, the limits for the relevant LTPs are specified in this section. The impact of public lighting shall be assessed independently of other lighting impacts.

4.2 Assessment of conformance

Conformance to the limiting values specified in [Table 4.2](#) shall be assessed on the basis of calculations of the applicable light technical parameters.

Luminous intensity limits shall not apply to public lighting.

The vertical illuminance limits shall only apply during the curfew period.

4.3 Public lighting zones

4.3.1 Basis for differentiation of limits according to zone type

The definitions of public lighting zones are described in [Table 4.1](#).

Table 4.1 — Public lighting zones

Public lighting zones	Ambient light conditions	Description
V	Traffic routes	Residences near Major Roadways with streetlighting (e.g. subcategory V public lighting scheme as per AS/NZS 1158.1.1)
R1	Local roads with significant setback	Residences near Local roads with streetlighting (e.g. subcategory PR public lighting scheme as per AS/NZS 1158.3.1) where the window line is greater than 10 m from the property boundary
R2	Local roads	Residences near Local roads with streetlighting (e.g. subcategory PR public lighting scheme as per AS/NZS 1158.3.1) where the window line is at or less than 10 m from the property boundary
R3	Roundabout or local area traffic management device	Residences near roundabouts or local area traffic management device with streetlighting (e.g. subcategory PR public lighting scheme as per AS/NZS 1158.3.1) where the window line is at or less than 10 m from the property boundary
RX	Pedestrian crossing	Residences near a pedestrian crossing with lighting (e.g. a subcategory PX public lighting scheme as per AS/NZS 1158.4) where the window line is at or less than 10 m from the property boundary

4.3.2 Public lighting zones for public lighting schemes as determined by AS/NZS 1158.3.1

The lighting zone for each sub-category for Category P installations are as follows:

- (a) Sub-category PR shall use Public lighting zone (R1-R3) limits, as applicable.
- (b) Sub-category PP and PC where part of a road reserve shall use public lighting zone (R1-R3) limits, as applicable.
- (c) Sub-category PP where not part of a road reserve shall use environmental zone (A0-A4) limits as applicable except that the Upward Light Ratio (UWLR) is to be as specified in AS/NZS 1158.3.1.

- (d) Sub-category PA and PE shall use environmental zone (A0-A4) limits as applicable except that the Upward Light Ratio (UWLR) is to be as specified in AS/NZS 1158.3.1.

4.4 Limits for light technical parameters

- (a) Vertical illuminance — The vertical illuminance shall be assessed on the windows of habitable rooms as required, according to [Clauses 3.3.1.2 to 3.3.1.6](#). [Figures 3.1](#) and [3.2](#) illustrate the application of the limits for E_v .
- (b) Threshold increment — Threshold increment on transport corridors affected by the public lighting systems shall conform to the limits in [Table 4.2](#) and calculated in accordance with [Clause 3.3.1.7](#).
- (c) Upward light ratio — An upward light ratio shall conform to the limits in [Table 4.2](#) and be calculated in accordance with [Clause 3.3.1.8](#). The Upward Light Ratios (UWLR) for sub-categories PR, PP, PA, PE and PC where part of a road reserve are to be as specified in AS/NZS 1158.3.1.

Table 4.2 — Public lighting — Maximum values of light technical parameters

Zones	Maximum vertical illuminance (E_v) lux		Threshold increment (TI)		Upward light ratio
	Non-curfew	Curfew	Maximum TI %	Default Adaptation level (L_{ad}) cd/m ²	Maximum ULR
V	N/A	4	As specified in AS/NZS 1158.1.1		
R1	N/A	1	20	0.1	As specified in AS/NZS 1158.3.1
R2	N/A	2	20	0.1	
R3	N/A	4	20	0.1	
RX	N/A	4	As specified in AS/NZS 1158.4		

Section 5 Use of computer programs

Where computer programs are used for the calculation of illuminance, they shall be based on the inverse square law method. The record of the illuminance calculations should state the computer program that was used, including the specific version of that program.

The luminous intensity data used as input for the program shall cover all of the luminous flux emitted by the luminaire(s), not just the angles that define the useful beam.

The photometric data shall be substantiated by reference to test reports from a laboratory that meets the requirements of AS ISO/IEC 17025 or NZS ISO/IEC 17025

NOTE 1 Accreditation bodies that are signatories to the International Laboratory Accreditation Cooperation (ILAC) Mutual Recognition Arrangement (MRA) for testing laboratories may be able to offer accreditation against the requirements of AS ISO/IEC 17025 or NZS ISO/IEC 17025. A listing of ILAC signatories is available from the ILAC website (www.ilac.org). In Australia and New Zealand, the National Association of Testing Authorities (NATA) and International Accreditation New Zealand (IANZ) are signatories to the ILAC MRA.

The photometric data used shall have angular intervals in the vertical planes not greater than 2.5°, and in azimuth the interval shall not be greater than 10°.

For road lighting, the photometric data shall have angles in the vertical and azimuth planes in accordance with the format described in AS/NZS1158.2.

NOTE 2 The file may have more supplemental values at intermediate angles in addition to those described in AS/NZS1158.2.

Appendix A (informative)

Design, installation, commissioning and maintenance guidelines

A.1 Introduction

This Appendix provides guidance on measures that can help mitigate the adverse effects of obtrusive light. These measures relate to the design, installation, operation, and maintenance of outdoor lighting.

The greatest potential for achieving satisfactory control of spill light is at the design stage. The emphasis of the advice given in this appendix is, therefore, on measures relating to the design of new installations. However, this advice may also be applicable for remedial action that may be taken for existing installations.

Many lighting installations, e.g. sports lighting, public lighting and outdoor workplaces lighting, involve conformance with specific requirements. This document deals with the consequential effects and does not relieve the designer from conformance to the original design brief and objectives of the project.

The design methods for horizontal areas such as sports fields, paths, roads and public spaces have differences compared to the methods for vertical surfaces and objects. They have therefore been separated.

A.2 Principles of obtrusive light mitigation

The primary purpose of an outdoor lighting installation is to satisfy visual needs for safe and efficient task activities, or amenity. Obtrusive light should be kept as low as reasonably achievable without significant compromise of the primary purpose.

The following design principles will help mitigate the adverse effects of obtrusive light:

- (a) A competent lighting designer should be employed. Controlling obtrusive light is often complex, requiring specialist skills, experience, software, and equipment.
- (b) Use light only where needed. Only use light for specific purposes. Only light the area or object intended. Note in some situations it may be beneficial to have a degree of light spill, e.g. pathway surrounds.
- (c) Use light only when needed. Have controls to switch off, dim, and change colour or dynamic aspects of the lighting when it is not required. A curfew could be introduced. Refer to the AS/NZS 1158 series for adaptive lighting controls.
- (d) Use only the amount of light needed. Do not over light. Specific light technical parameters exist for most applications; refer to relevant Standards and guidance from lighting institutions. Lighting should meet the limiting values required but not exceed them by more than necessary.

NOTE Designs should also responsibly account for accuracies and tolerances.

- (e) Use appropriate luminaires and light sources. Take account of other features and benefits beyond initial cost and energy efficiency, e.g. the range of light distributions, light outputs, spectral power distribution (SPD), shielding options, durability, and rigidity. Luminaires with flexible mounting may “flutter” due to wind and become more distracting and annoying.

- (f) Use luminaire optics with appropriate intensity distributions.
 - (i) Intensity distributions with rapid ‘run-back’ or ‘cut-off’ at the edges of the beam can limit the amount of light spill and upward light.
 - (ii) When using floodlights for area lighting, where appropriate use luminaires with asymmetric beams where the light emitting surface can be kept at, or near parallel to the surface being lit.
- (g) Use appropriate luminaire locations and aiming as follows:
 - (i) To minimize sky glow direct light beams downwards. If there is no alternative to up-lighting, then use directional luminaires, shields and baffles. Where possible, keep up-lighting luminaires below overhangs to limit the spill light into the sky.
 - (ii) When using floodlights determining the right mounting height is an important factor. Too low and the necessarily higher tilt angles will result in higher intensities at higher angles with consequentially higher spill and upward light. Too high and light spill can be difficult to contain within the intended area.
 - (iii) Direct lighting where it will not shine directly on highly reflective surfaces (including the surface of natural and artificial bodies of water). Surfaces that are to be illuminated should as far as possible be non-reflective.
 - (iv) As far as possible avoid directing light onto surfaces that are frequently wet, because water increases reflectivity and disorients wildlife by mimicking the surface of natural water bodies.
- (h) Use light sources with appropriate spectral power distributions (SPD).
 - (i) Light sources with relatively blue-rich SPD should be avoided as radiation at the blue end of the spectrum may increase sky glow. Preference should be given to CCT of 3000 K or lower. For CCT in public lighting refer to SA/SNZ TS 1158.6. Note that the concept of CCT, and colour rendering index (CRI) is useful for visual perception only, it does not give an indication of SPD. Light source SPD should be considered and selected based on all factors relevant to the particular objective/application.
 - (ii) Sports fields have high levels of human activity, and task difficulty where visibility is essential, and often taking place during sunset. Sources of up to 5700 K (“daylight”) can satisfy end user preferences while mitigating other adverse effects when implemented by a competent person.

A.3 Reflective properties of an illuminated surface

Conformance to this document is based on direct illuminance only and that has been assumed in the setting of the vertical illuminance limits. The designer and relevant authorities however should be aware of the impact that surface reflectance can have on the overall obtrusive impact of the installation, particularly if it is specular, or exceeds 0.7.

The reflected illuminance component will depend on the intrinsic reflecting properties of the illuminated surface. In many cases the reflected illuminance will be lower where natural grass or asphaltic surfaces are used, but may be significant where the surface is relatively light in colour, e.g. uncoloured concrete, artificial grass with sand infill, or light coloured walls. The reflective properties of the surfaces may vary from season to season, and from year to year. The reflectivity of some materials is not uniform. For example, the reflectance of artificial grass depends on the orientation of the grass and the amount of sand that has been laid. Weathering may also affect the affect the reflectance and diffusion of surfaces over time.

Where there is a choice of surfaces, it is desirable that a surface with the lowest practical reflectance be selected, compatible with the function of the area. Note that reducing the reflectance of the ground plane may increase the surface temperature in daytime.

A.4 Installation and commissioning

The approved lighting design is required to indicate the aiming direction and tilt of all luminaires. If the installation is altered with respect to equipment selection or location, then it can no longer be assumed that the installation will still conform to this document.

A.5 Maintenance

Ongoing conformance to this document is dependent on good maintenance. A build-up of dirt on the luminaires may scatter the light and increase the light spill. Ensure that the aiming of the luminaires is not altered by unintended luminaire movement that may be caused by wind, vibration, impact, cleaning, re-lamping or any other maintenance requirements.

A.6 Design guidelines for horizontal areas

A.6.1 Spill light

Spill light associated with a lighting installation for a horizontal area can be obtrusive when it detrimentally impacts surrounding areas, e.g. dwellings, transport, environmentally sensitive areas, and astronomical observations, see [Clause 2.3.4.1](#).

For sports lighting and similar tasks with a defined area, some light bleed into the area immediately surrounding the specified playing area can be useful as a background for tasks, for amenity, or safety, and may reduce the need for supplementary lighting. Spill light over the boundary is undesirable and will generally lower the efficiency of the lighting installation..

A.6.2 Location of illuminated area/activity

As the vertical illuminance is reduced by the square of the distance, a buffer zone between the area to be lit within the lighting installation and the surrounding boundaries will reduce the vertical illuminance and can also reduce the impact of the luminous intensity.

When there is some flexibility as to where the illuminated area/activity can be placed, it should be located and oriented where it will have the least effect on the environment or existing or potential developments. Advantage should be taken of any screening that may be provided by the surrounding topography or other physical features, e.g. buildings, trees or earth embankments.

A.6.3 Selection of luminaires and light distribution

The selection of luminaires can have a significant effect on the ability to control the light that is emitted outside the boundaries of the properties. It is important that the selected luminaire has a light distribution that is appropriate not only for the overall lighting task, but also to minimize obtrusive light. As a general principal lighting installations that control obtrusive light well will be generally more efficient at lighting the task.

[Figure A.1](#) gives simplified indication of the different types of luminaires and the impact that it has on obtrusive light. It shows preferred and non-preferred luminaire light distributions.

[Figure A.2](#) indicates how the distribution of the luminaire can affect the ability to control obtrusive light. Avoid the use of luminaires that do not have the ability to control, shape, or shield the spread of the light, particularly at the edges of the beam. A lighting installation may benefit from a variety of different distribution types that have different abilities to restrict over-spill at the front of the beam, back-spill, and side-spill.

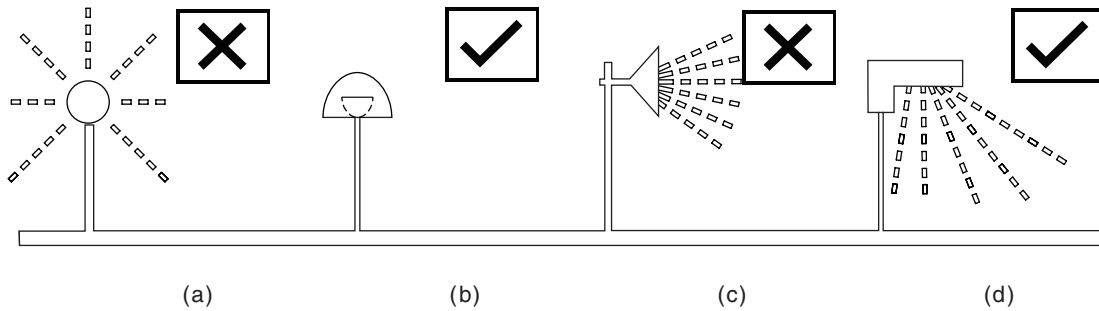

Figure A.1 — Simplified lighting types and their ability to control obtrusive light

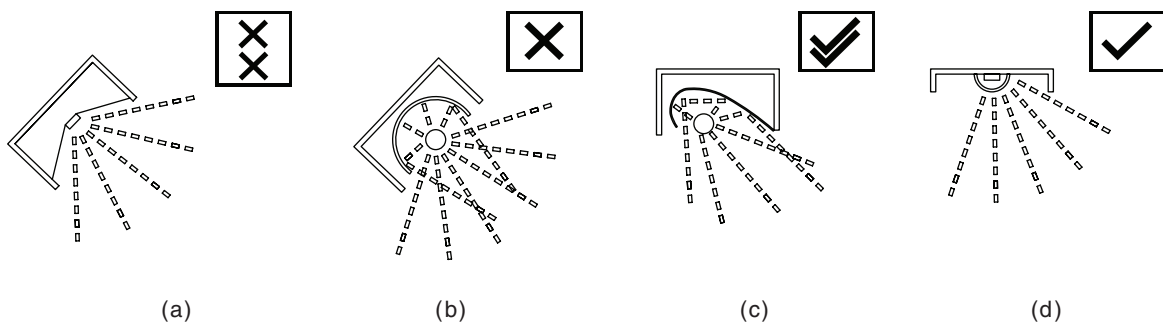

Figure A.2 — Effect of the light distribution of the luminaire on the ability to control obtrusive light

A.6.4 Location and aiming of luminaires

As the illuminance reduces in proportion to the inverse of the square of the distance from the luminaire, it follows that the greater distance the luminaires can be located from the affected property, the lower will be the illuminances at, and beyond the property boundary. The suboptimal location of luminaires and aiming direction can limit the ability to contain the light within the boundaries. As the vertical illuminance is reduced by the square of the distance, a buffer zone between the area to be lit within the lighting installation and the surrounding boundaries will reduce the vertical illuminance.

Luminous intensity does not decrease with distance to the observing position. Shielding and aiming is the primary way of controlling luminous intensity. As the vertical aiming angle, or uplift, of a luminaire is increased there is generally an increase in the distance where relatively high levels luminous intensity is visible. Depending on the light distribution of the luminaire increasing the uplift may also result in a greater upward light ratio.

The objective of the design should be to ensure that, as far as is practicable, direct view of the bright parts of the luminaires is prevented from potential viewing positions beyond the intended area to be illuminated. Where possible, advantage should be taken of the shielding which may be provided, e.g. evergreen trees, embankments, spectator stands or other physical features.

The back-spill of the luminaire (the light that is emitted behind the luminaire) will determine how closely the luminaire can be mounted to the adjacent property.

[Figure A.3](#) indicates how the combination of light distribution and aiming angle can influence the control of the spill light. Asymmetrical distribution luminaires can have the peak intensity at a higher angle while having zero or restricted light above the horizontal plane. This limits the spill light into the sky and the impact of the light on nearby affected properties.

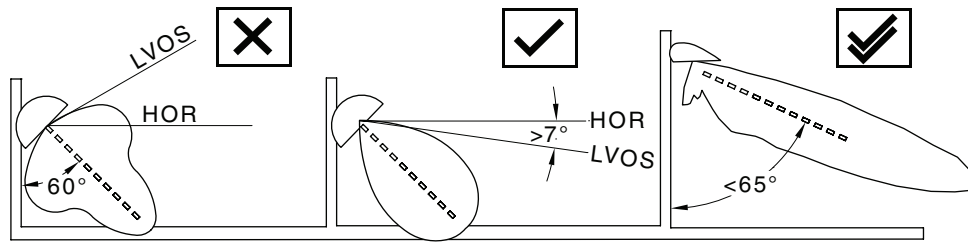
**Key**

LVOS = Limit of view of source

Figure A.3 — Effect of aiming angle light distribution

A.6.5 Luminaire mounting height

When determining the mounting height of the luminaires, consideration should be given to the following:

- (a) Higher mounting heights may —
- (i) be more effective in controlling spill light because luminaires with a more controlled light distribution (i.e. narrower beam), and allow the luminaires to be aimed in a more downward direction, provided that tighter beam luminaires are used, making it easier to confine the light to the design area;
 - (ii) decrease the angle of incidence so that the efficiency of the lighting is improved;
 - (iii) result in more scattering in the local atmosphere;
 - (iv) allow fewer luminaires and locations by using higher output luminaires; and
 - (v) if excessively high, increase spill light for a given light distribution due to a consequentially larger illuminated “foot print”.
- (b) Lower mounting heights may —
- (i) have the advantage of making the lighting installation less obtrusive by day;
 - (ii) increase spill light because, to illuminate the space satisfactorily, as it will often be necessary to use luminaires with a broader beam and to aim the luminaires at higher angles;
 - (iii) require careful selection of luminaires or more luminaires and locations to achieve desired illuminance uniformity; and
 - (iv) decrease spill light for a given light distribution due to a consequentially smaller illuminated “foot print”.

The principles described above are illustrated in [Figure A.4](#).

The use of a combination of luminaires with different light distributions, and outputs at different mounting heights can be used to provide an optimised lighting installation for site specific conditions.

For sports lighting applications, AS 2560.2 provides recommendations for the location, and mounting heights of luminaires as a glare control measure for participants.

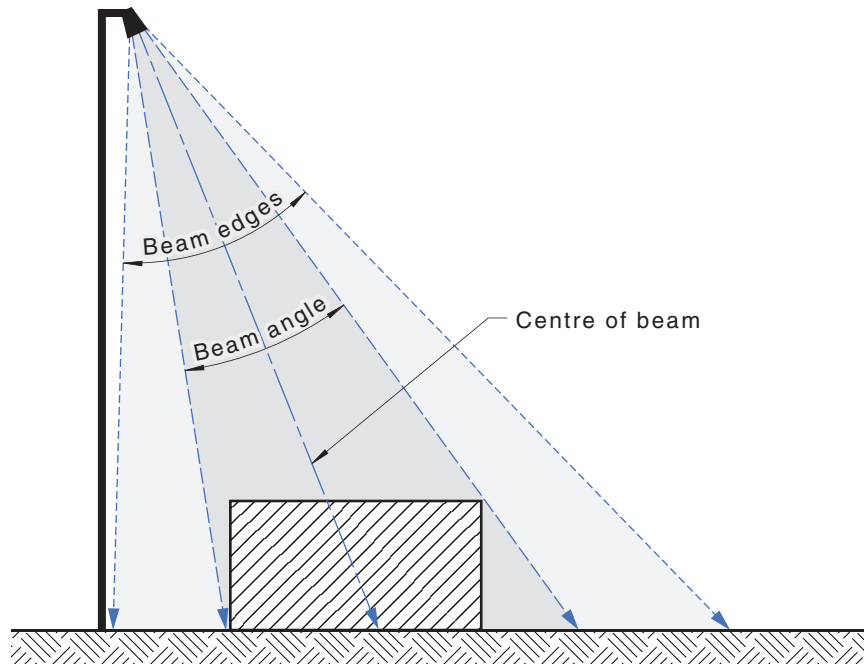

(a) High mounted luminaire with narrow beam width and shielding to prevent spill light

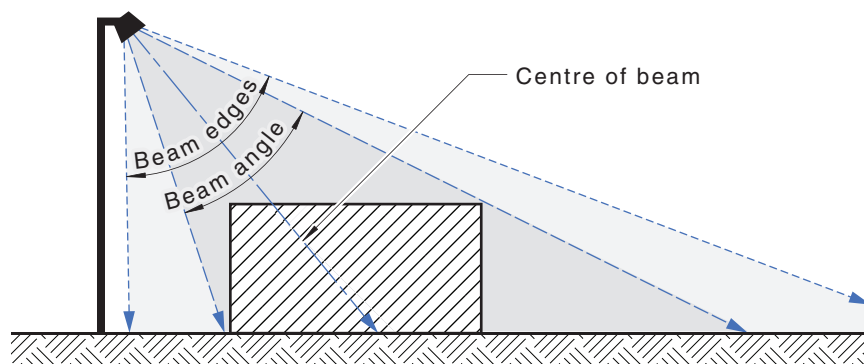

(b) low mounted luminaire with shields to prevent spill light

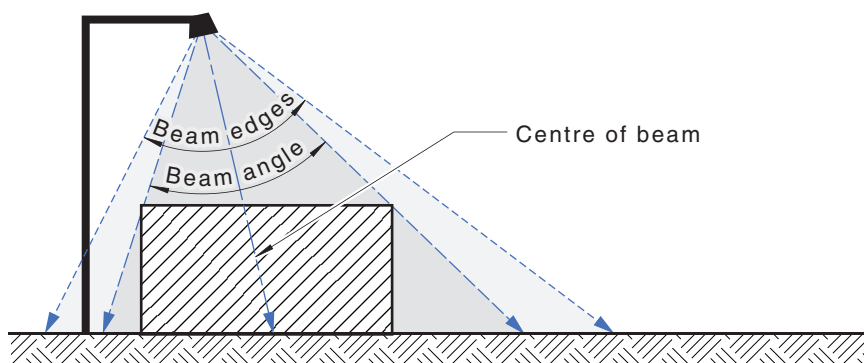

(c) Overhanging symmetrical luminaires to be used on poles located closer to the intended area.

NOTE 1 Lower mounting height means that a higher aiming angle is required and a wider beam.

NOTE 2 As the light distribution is symmetrical the higher aiming angle means that there is direct view of the lamp.

NOTE 3 The cut-off angle indicates the point at which there is no view of the lamp or flashed reflector.

NOTE 4 At low mounting angles the cut-off is often above the horizontal.

NOTE 5 With a forward throw distribution the light has the same or better coverage area as the wide beam light above but the forward throw means that the area can be covered with no light above the horizontal plane.

Figure A.4 — Effect of mounting height and beam angle on spill light

A.7 Design guidelines for externally illuminated vertical objects

A.7.1 General

With vertical objects,(e.g. signs, facades), the luminaire location, type of luminaire, and aiming is often restricted by site specific constraints. These suboptimal conditions will necessitate pragmatic compromises regarding the desired outcomes of the primary purpose of the lighting installation, and obtrusive light control.

The location and nature of the object to be illuminated may create physical limitations on locations of the luminaires due to property ownership extents, pedestrian and vehicular traffic movements, or daytime aesthetics. Luminaires often need to be located relatively close to the target area.

Whereas most horizontal surfaces are lit to conform with the requirements of a particular code or standard, typically for sport or public lighting, most vertical tasks are lit for aesthetics or promotional purposes. There are rarely standards for illuminance or uniformity.

In some situations, a more interesting visual effect may be achieved by selectively lighting highlights rather than blanket uniform lighting of the surface.

A.7.2 Luminance limits

The limiting levels of luminance in [Table 3.4](#) are set to limit the obtrusive light impacts of the lighting. They should not be taken as recommended design levels for facades. Most facades can be effectively lit to much lower levels of luminance. Site trials can be useful to establish the subjective impression for a given site context and ambient lighting conditions.

A.7.3 Location and aiming of luminaires

The setback distance of a luminaire to the vertical object is the equivalent to the mounting height for a horizontal area. Generally, the most effective and efficient location of a luminaire is perpendicular to the surface to be lit; however, this is rarely practical.

When lighting a vertical surface from below a short setback will result in poor uniformity up the face of the building, and also light spill from “overshoot”. Due to the high angle of incidence, the efficiency of the illumination will be relatively low as a result of the cosine factor. This will result in more luminous flux required to achieve the same illuminance. For example, approximately twice the luminous flux is required if the angle of incidence is reduced from 45 to 25 degrees and more flux overshoots to generate sky glow.

For a vertical surface with a luminaire mounted above or below, for a given point at a constant height, the optimal balance between the inverse square, and cosine effects as the luminaire is moved closer and further from the wall, is an aiming angle such that the angle of incidence is approximately 55°. This will give the most efficient solution, provided the luminaire light distribution is appropriate. The aiming angle will determine the offset distance from the wall.

A combination of different beam angles can be used to closer relate to the shape of the surface to be illuminated.

The location of a luminaire can influence the potential for light spill into the sky, as indicated in [Figure A5](#). Additional control measures to limit the spill light into the sky may be achieved by capturing

the light overshoot with an obstruction ([Figure A5\(a\)](#)), lighting from above ([Figure A5\(c\)](#)), or using a greater setback and a luminaire with a relatively narrower beam with a sharp cut off at the top of the distribution ([Figure A5\(d\)](#)).

Externally lit signs and billboards should be lit from the top.

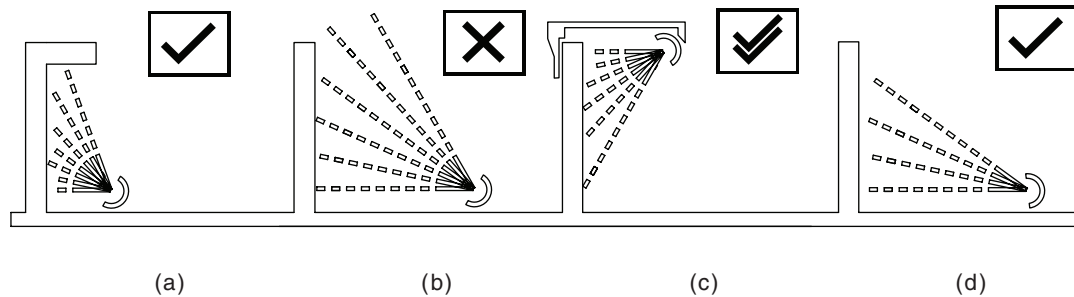

Figure A.5 — Effect of luminaire location upward spill light

A.7.4 Spill light

Unlike horizontal areas, spill light associated with vertical objects often passes the target object so that it can be a direct source of obtrusive light. In addition, spill light on objects surrounding the task object can detract from the lighting effect.

If an object is to be lit so that the lighting appears to be uniform it is often easier to use a luminaire with a relatively wide distribution. While this may produce the desired visual impact, it is generally less efficient and generates significant spill light, see [Figure A6\(a\)](#). Luminaires with a narrower light distribution reduces the overshoot improving illumination higher up, and efficiency, see [Figure A.6\(b\)](#).

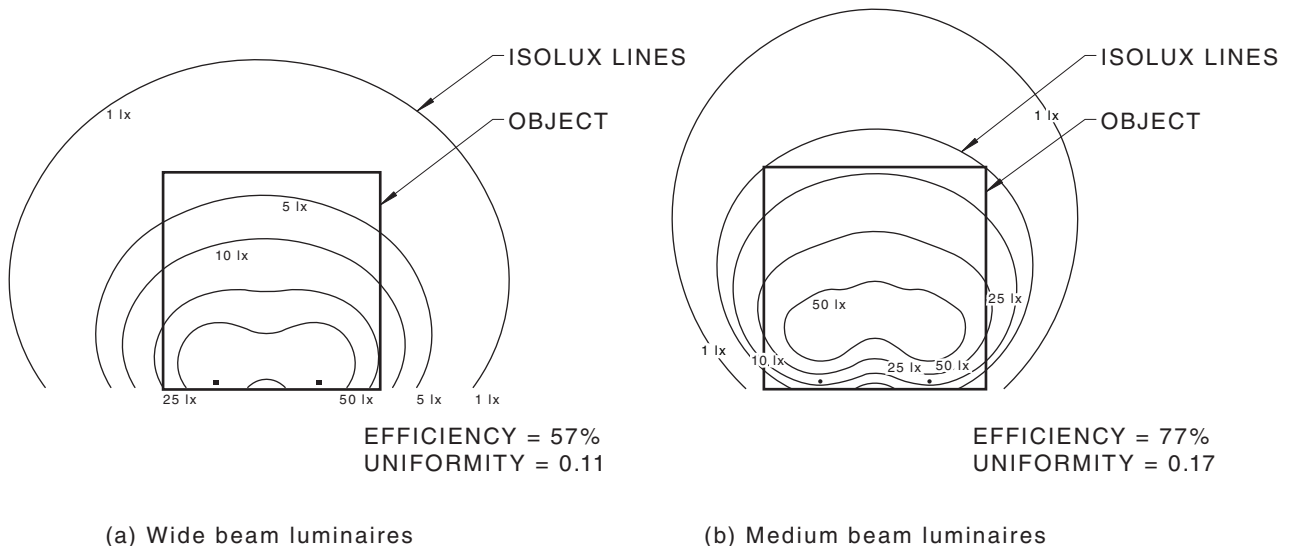

Figure A.6 — Example of vertical object lit with different beam types

While maintaining illumination higher up, luminaires that are too close will increase spill light to the sky due to the larger angle of incidence, see [Figure A.7\(a\)](#). Efficiency and uniformity can be improved while minimising spill light by using relatively more luminaires with a relatively lower output, see [Figure A.7\(b\)](#). While relatively uniform, especially lower down, the illuminance falls off higher up if too close.

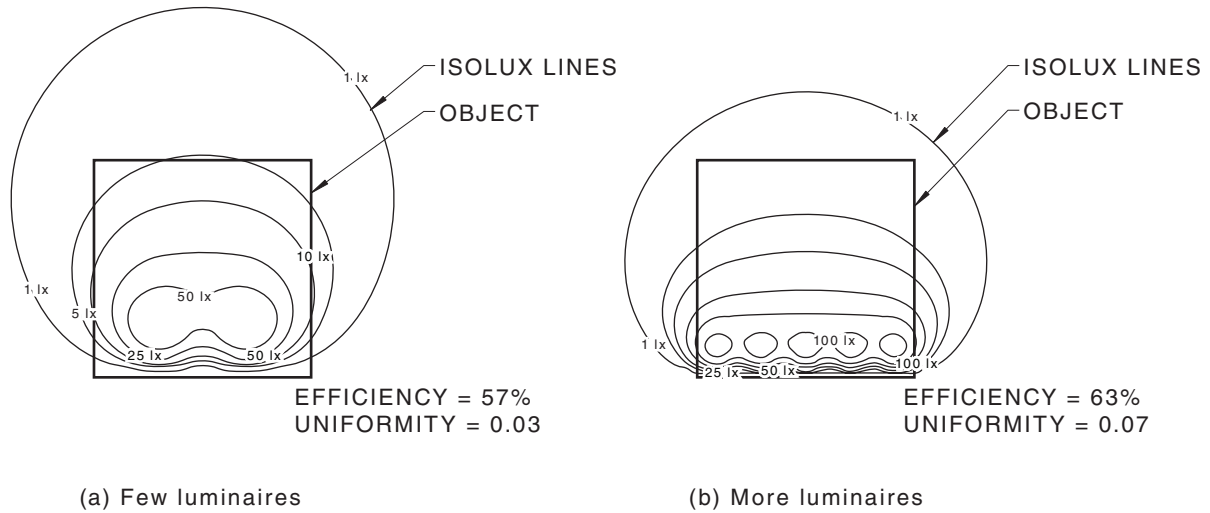

Figure A.7 — Example of vertical object lit with relatively close luminaires

A combination of wider beam luminaires covering lower parts, and more narrow beam luminaires covering the upper parts may provide more uniform lighting, and also more focused light reducing spill light, see [Figure A.8](#).

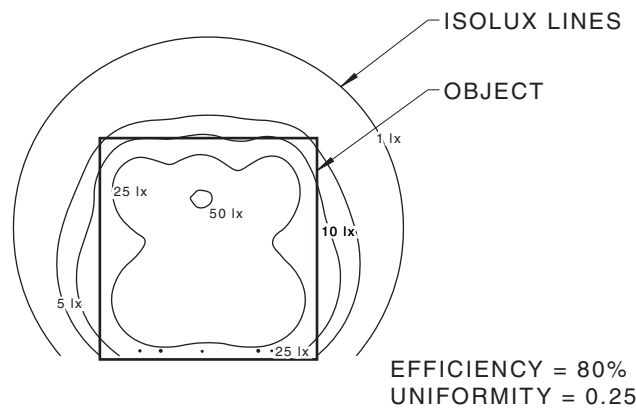



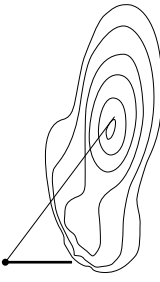

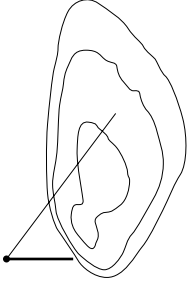
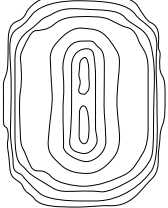

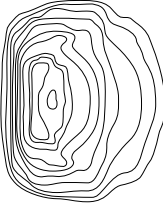

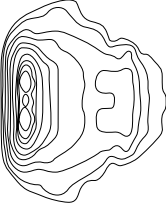

Figure A.8 — Example of vertical object with wide and narrow beam types

A.8 Classification of luminaires for floodlighting

[Figure A.9](#) shows a simple classification of floodlights that has been developed for sports lighting. AS 2560.1 classifies luminaires by the beam shape and directional qualities of the light distribution. Luminaire distributions that are asymmetrical give the ability to direct the light without projecting light at angles near the horizontal direction and above.

Louvres, baffles or shields may be fitted to floodlights to control spill light. These may be internal or external. The baffles and louvres will affect the photometric distribution of the light and may affect conformance to the original functional requirements for the lighting installation. Photometric files that have been created with any such shield accessories should be used. Note that the mechanical strength of the luminaire fixings and supports may be affected because of the additional wind loading the devices impose.

Figure A.9 — Classification of exterior floodlights

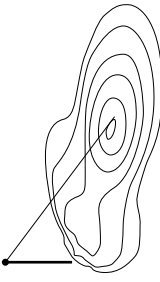
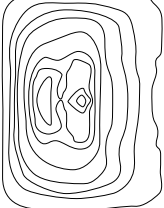
Type	Typical appearance	General description	Characteristic beam shape	Characteristic cartesian intensity distribution
A		<p>Rotationally symmetrical projector giving a circular shaped beam with a typical beam angle of 5°-40°. The peak intensity is generally normal to the light emitting surface. The light emitting surface may have an uplift from 45°-70° in normal application.</p>		
B		<p>Bi-symmetric floodlight giving a rectangular shaped beam. The beam angle may be similar in the vertical and horizontal planes, or may be narrower in the vertical plane ('letterbox'). Beam angles may be 50°-70° horizontally, and 15°-40° vertically. The peak intensity is normal to the light emitting surface. The light emitting surface may have an uplift from 45°-70° in normal application.</p>		
C		<p>Asymmetrical in the vertical plane giving a fan shaped beam. The peak intensity is typically 30°-40° above the normal to the light emitting surface. The light emitting surface may have an uplift from 0°-40° in normal application. There is some 'run-back' of intensity above the peak intensity.</p>		
C cut-off		<p>Asymmetrical in the vertical plane giving a fan shaped beam. The peak intensity is typically 60° to the normal to the light emitting surface. The light emitting surface may have an uplift from 0°-10° in normal application. There is rapid 'run-back' of intensity above the peak intensity</p>		
D		<p>Asymmetrical in the vertical plane giving a fan shaped beam. The peak intensity is typically 30° to 65° above the normal to the light emitting surface. The luminaire is non-aimable and light emitting surface is fixed at 0° in normal application (it may be set at up to 20° with appropriate fixings). There is rapid 'run-back' of intensity above the peak intensity</p>		

Appendix B (informative)

Design documentation

B.1 Scope of Appendix

This appendix sets out the information that should be provided to the relevant authority to facilitate assessment of a proposed lighting scheme for conformance to environmental design objectives, particularly those objectives that relate to the light technical parameters given in [Tables 3.2 to 3.4](#) and [Table 4.2](#) when required for public lighting. See also [Clause 1.4](#) with respect to demonstrating conformance to the requirements of this document.

The provision of much of the information needed to facilitate the design, particularly to satisfy the environmental objectives, is the responsibility of the client.

The client should also make the lighting designer aware of any additional requirements or differences in the format of information needed by the relevant authority that is to assess the particular development.

The lighting designer should demonstrate conformity of the design of the installation with the light technical parameters of [Tables 3.2 to 3.4](#) and [Table 4.2](#) when required for public lighting.

B.2 Statement of objectives

A statement should be provided indicating the design objectives for the lighting installation, including—

- (a) the proposed lighting levels for the activity, including reference to relevant Australian or Australian/New Zealand Standards or other authoritative lighting provisions, as appropriate; and
- (b) the environmental factors that have been taken into account, the specific features of the design which have been incorporated and how they overcome existing or potential problems.

B.3 Supporting documentation

B.3.1 Information relating to the environment

The following information should be provided on the environment in which the Lighting Installation is to be located:

- (a) Details of the facility to be lit, including; its location on the site, the nature of the surface to be illuminated, and the nature and location of adjacent properties, particularly those properties most likely to be affected by spill light.
- (b) The nature and location of physical features (e.g. spectator stands or trees) that might restrict spill light.
- (c) Topographical information for the site of the proposed lighting system including data on height differences of adjacent properties relative to the site.
- (d) Details of any transport system in proximity to the lighting installation that utilizes signalling systems that may be affected.

- (e) Details of any road lighting or other public lighting existing in the immediate vicinity of the proposed lighting installation and any information needed to support the operational functionality of control systems.
- (f) Details of the locations of nearby astronomical observatories that may be affected by spill light (see Clause 2.3.4).
- (g) Details of any nearby environmentally sensitive areas.

B.3.2 Information relating to the lighting installation

The following information relating to the lighting installation should be provided:

- (a) A statement of the design objectives for the lighting installation.
- (b) Plans illustrating the geometric relationship between the locations of the luminaires and calculation points considered in the design.
- (c) Details of the luminaires including catalogue number, photometric files, luminous flux and maintenance factor(s).
- (d) The computer program and version used for the calculations . See [Section 5](#)
- (e) Calculated values of the relevant light technical parameters and other information needed to support the basis of the design (see [Tables 3.1 to 3.4](#) and [Table 4.2](#) when required for public lighting).
- (f) Information needed to support the operational functionality of control systems.
- (g) Aiming angles and mounting heights for all luminaires.
- (h) A declaration of conformance to this document and compliance with any applicable legislative or statutory requirements.

Appendix C (informative)

Impact of outdoor lighting on flora and fauna

C.1 Introduction

This appendix provides general guidance on the impacts of artificial light on the environment, legal obligations under Australian and New Zealand environmental regulation and the environmental impact assessment process. Details for the New Zealand environmental regulatory requirements relevant to light pollution are not provided. For specific information on environmental regulation advice should be sought from the relevant authority in both Australia and New Zealand. For any lighting project where light is visible outdoors the risk assessed and adaptive management framework described in the [Convention on the Conservation of Migratory Species of Wild Animals \(CMS\) Light Pollution Guidelines for Wildlife](#) can be applied by anyone in any jurisdiction and context.

C.2 Effects of artificial light on plants, animals and ecosystem function

As all life on earth has evolved under predictable patterns of light and darkness, most organisms are highly adapted to respond to changes in natural light cycles (including daily, lunar and annual fluctuations). As a consequence, the environmental impacts of artificial light are varied and complex. Artificial light at night can affect the physiology of plants and animals, behaviours and migratory patterns of animals, and ecosystem processes. These effects are likely to be greatest when introducing artificial light into naturally dark places.

Artificial light can affect the structure of ecological communities. For example, nocturnal lighting can alter the timing of growth, flowering and senescence in plants, which may have flow-on negative implications for pollinators and herbivores. Conversely, changes in the abundance of pollinators can have implications for plant reproduction. Even apparent benefits may actually be ecologically costly. Insect predators (insectivores) may gain increased foraging success around street or other lights due to the large number of light-attracted insects that gather there. However, light attracted insects have a higher risk of predation and may simply die from exhaustion due to being “trapped” by the lights. This in turn may change insect population structure and lead to long-term declines in insectivore numbers. Changes to prey abundance are likely to have implications for predatory species.

Effects of artificial light on wildlife can include behavioural changes (including disorientation and other shifts in activity and sleep patterns), and physiological impacts (including reduced reproductive success or survival and compromised immunity). Light-related disorientation occurs when an animal’s natural visual cues are overridden by more dominant artificial light and an animal is unable to perform natural behaviours. Behavioural impacts can be mediated through a perceived or real increase in predation risk (i.e. predators can more easily see prey), which causes prey species to avoid leaving a refuge, stop them foraging or undertaking other biologically important behaviours. Actual predator/prey relationships may also change under altered light conditions, which can lead to population scale shifts in the abundance of some groups. Physiological impacts occur when hormones that are naturally mediated by changes in daily patterns of light are instead regulated, masked or otherwise subject to interference by the presence of artificial light. While species may vary in their ability to detect or see different colours of light, the physiological effects of light at night are often mediated specifically by the presence of blue wavelengths of light.

The largely negative effects of light at night can be caused by the presence of light sources in the immediate vicinity, as well as from sky glow (scattered light originating from a light source that may be tens of kilometres away). The impacts of light at night extend beyond species living in terrestrial environments; marine and other aquatic organisms have also evolved under constant light cycles and

use light intensity and spectra as cues. Light at night in aquatic systems can affect vertical migration patterns of plankton and other organisms and may interfere with offspring production and hatching in fish.

The environmental effects associated with natural variation in light occur at very low light levels (e.g. predator/prey interactions and nocturnal singing behaviour in birds can be altered by the waxing and waning of the moon), and different organisms may be sensitive to different wavelengths of light, including some outside of the human visual spectrum. Introduction of artificial light into naturally dark areas will result in the greatest environmental impact; however, due to the scattering of light particles, the cumulative impacts of many light sources can be significant within the local environment but may also influence ecological processes up to tens of kilometres from the source.

Where artificial light is present in environments in which protected species or ecological communities are found, artificial light has the potential to significantly affect a protected species or ecological communities through, for example, stalling the recovery of a threatened species or community or disrupting the lifecycle of a migratory species. The limits identified in [Tables 3.2 to 3.4](#) and [Table 4.2](#) have not been derived to address specific species or ecological community needs and so conformance with this document may not be sufficient to meet environmental regulation. To address these considerations for specific listed entities, a risk assessed, and adaptive management approach should be undertaken consistent with the *Light Pollution Guidelines for Wildlife*.

C.3 Self-assessment of whether an action should be referred under the Australian Environment Protection and Biodiversity Conservation Act 1999

The *Environment Protection and Biodiversity Conservation Act 1999* (EPBC Act) is the Australian Government's central piece of environment legislation. For the purposes of the EPBC Act, a self-assessment should be undertaken to determine whether a proposed action will need formal assessment and approval under the EPBC Act. A referral will be the principal basis for the Minister's decision as to whether approval is necessary.

Below is a list of Australian Government resources that can assist in determining whether or not lighting projects may need to be referred under the EPBC Act. In accordance with the EPBC Act, it is an offence to have a significant impact on a [Matters of National Environmental Significance](#) (MNES).

The resources are as follows:

- (a) To determine whether lighting that is visible outdoors is likely to have a significant impact, the [Environment assessment and approval process](#) for understanding how the EPBC Act may or may not apply.
- (b) The department's [Protected Matters Search Tool](#) for generating a report that summarizes [MNES](#) that may occur in, or adjacent to, your project area.
- (c) The [Species Profile and Threats Database \(SPRAT\)](#) for finding out more information about protected species and ecological communities.
- (d) The [Significant Impact Guidelines](#) 1.1 can assist in deciding whether the proposed project is likely to have a significant impact on the environment.
- (e) Where artificial lighting may potentially have a significant impact on a MNES, the [CMS Light Pollution Guidelines for Wildlife](#) provides a risk assessed and adaptive management approach to managing light for the benefit of listed species and ecological communities.

For any lighting project where light is visible outdoors the risk assessed and adaptive management approach described in the CMS [Light Pollution Guidelines for Wildlife](#) can be used by anyone.

C.4 Environmental Impact Assessment Overview

Environmental Impact Assessment (EIA) is a process of evaluating the likely environmental impacts of a proposed project or development, considering the inter-related socio-economic, cultural and human safety impacts, both beneficial and adverse. EIA is a tool used to identify potential impacts at an early stage in project planning and design and devise solutions to avoid adverse impacts. By using an EIA approach both environmental and economic benefits can be achieved by avoiding treatment and cleanup costs, project time increases and inconsistency with laws and regulations. This tool is commonly used to assess proposed developments in relation to environmental legislation, but the concept can be scaled to any sized project.

For further details about applying an EIA to lighting projects refer to the *CMS Light Pollution Guidelines for Wildlife* and ancillary documents.

Appendix D **(informative)**

Lighting of flags and banners

D.1 Introduction

The lighting of flags and banners is inherently inefficient due to the variation in the location of the flag. As a result, the majority of the light contributes directly to sky glow.

Where there is a requirement to light flags and flagpoles the lighting should be designed to maximize the efficiency of the lighting and the flags should not be overlit.

Consideration should be given to whether there is sufficient ambient illumination to adequately display the flags.

The closer the luminaires are to the base of the flagpole, the less efficient the illumination of the flag and the higher the contribution to sky glow.

The beam width of the light source should be minimised to match the span of the flag.

Where possible the luminaires should be located so that the angle of incidence of the light to the fully unfurled flag is less than 60 degrees

D.2 Utilization of flag illumination

For calculating the utilization of the flag illumination, the area of the calculation plane should be defined as shown in [Figure D.1](#)

The calculation plane shall be vertical and perpendicular to the luminaire, in plan view.

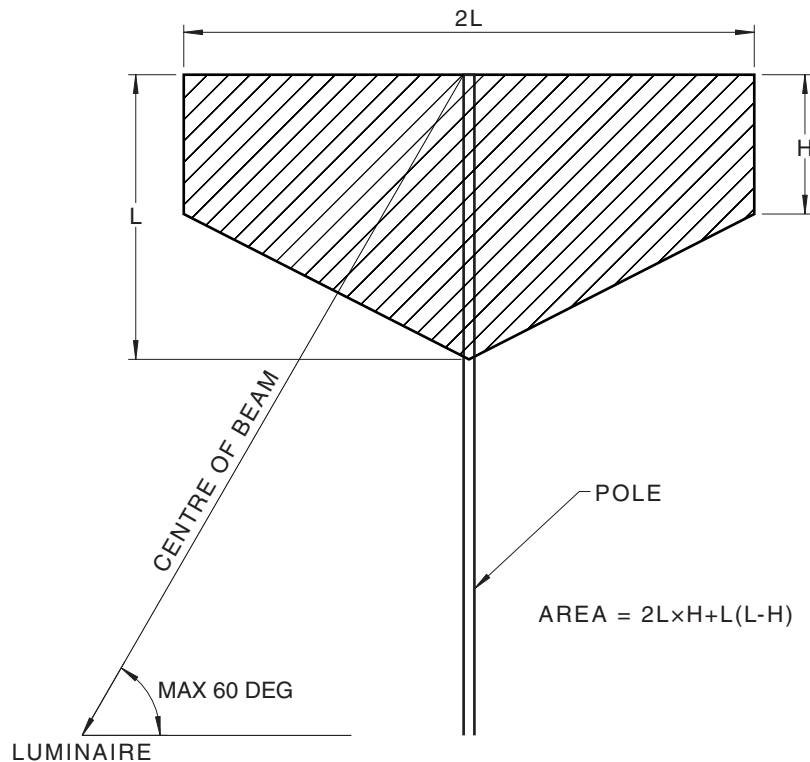

where

- L = length of the flag
 H = height of the flag

Figure D.1 — Area of calculation plane

$$UF = E_{av} \times A / \phi$$

D.1

where

- UF = utilization factor
 E_{av} = average illuminance of the flag calculation plane
 A = flag calculation plane
 ϕ = luminaire Flux

The utilization factor (UF) should not be less than 0.1

D.3 Flag illuminance

The required illuminance for a flag will depend on the viewing distance and the ambient environment. The flag should not be overlit as the lighting is designed to bring awareness to the flag rather than convey a specific message.

D.4 Selection of luminaire

The luminaire should be selected so that its beam width is close to the width of the flag calculation plane.

A luminaire that has a distribution that is elongated in the horizontal plane will provide a higher uniformity and lower utilization factor.

Appendix E (informative)

Field measurements

E.1 Scope

This Section provides guidance on illuminance and luminance measurements that may be required for the assessment of new or existing installations. Illuminance values are specified in [Tables 3.2](#) and [Table 4.2](#).

On site assessments may be required by an authority for situations where no photometric data are available to provide calculations of light technical parameters (LTP) or where the installation is not strictly in accordance with the design. This may also be required to confirm that the levels of obtrusive light are not excessive.

Measurement is not required for demonstrating conformance and where an installation is installed in accordance with a conforming design then it shall be deemed-to-conform, irrespective of measurements.

Where luminance measurements are to be undertaken to assess the LTPs in [Clause 3.3.3](#), guidance is provided in [Clause E.4](#).

E.2 Factors that influence the uncertainty of the results

Similar to lighting designs, on-site measurements are subject to many variables, and measurements need to be corrected for sources of error, or sources of error need to be accounted for in determining the acceptance limits for compliance assessments to the LTP limiting values in [Tables 3.2](#) to [3.4](#) and [Table 4.2](#).

These include but are not limited to—

- (a) Extraneous light as follows:
 - (i) Reflected light originating from the luminaires in the design.
 - (ii) Additional reflected light from other light sources.

NOTE Extraneous light may be compounded by wet surfaces.
- (b) Direct light as follows:
 - (i) From other light sources.
 - (ii) From the moon and overcast sky.
- (c) Variations in supply voltage.
- (d) Light sources as follows:
 - (i) Faulty luminaires.
 - (ii) Luminaires operating incorrectly.
 - (iii) Aged light sources.

- (iv) Build-up of dirt and bugs/webs on the luminaires.
- (e) Interference by trees, foliage or other obstructions.
- (f) Calibration of illuminance meters as follows:
 - (i) Accuracy.
 - (ii) Linearity.
 - (iii) Cosine response.
 - (iv) Spectral response calibration.

Correction should be made for all of the above calibrations using the calibration reports for the meter.

Knowledge of the spectral output of the luminaires is especially important when considering sources with large 'spikes' in the spectrum such as RGB LEDs, white LEDs, fluorescents and metal halides. Correction factors for these sources may be provided in calibration reports.

- (g) Uncertainty in measurement as follows:
 - (i) Light meter placement and orientation.
 - (ii) The resolution of a light meter.

The resolution of the light meter should be at least an order of magnitude greater than the calculated/measured values. This could significantly impact on the measured illuminance and also on intensities calculated from such measurements.

E.3 Check measurements

Credible measurements of the light technical parameters in [Tables 3.2](#) to [3.4](#) and [4.2](#) are often difficult to perform and can be complex or limited by access to relevant measurement locations and the ability to identify stable ambient lighting conditions. Where such measurements are requested, they should be undertaken by persons who are professionally qualified and competent in the discipline of illuminating engineering.

It will be necessary to compensate for the variables detailed in [Clause E2](#) and to take care to avoid extraneous light.

It may be easier to take two sets of measurements; one with the installation turned off and another with it turned on. The difference between the two measurements will be the approximate levels from the installation. The results will still include both the direct and reflected illumination components, whereas conformance with the standard is based on the direct illuminance only. It is not possible to isolate this reflected component in a field measurement. This method is only valid if the background contribution to the lighting is consistent for both measurements.

The measurements should be modified to allow for the factors identified in [Clause E2](#) including the supply voltage, if appropriate, and lumen depreciation.

It is not possible to directly measure the luminous intensity as a field measurement.

The measured levels will be higher than the calculated levels, and will include a reflected component. As a result, adjusted measurements may exceed the limits in this document but the installation may still conform if the reflected component of the illumination is subtracted.

As a result of the factors detailed above, the measured results can only be used as an indication of the lighting levels as a basis of discussion with the client rather than a definitive measure of conformance.

E.4 Luminance measurements

E.4.1 General

Luminance measurements are sometimes requested, as part of an approval, to demonstrate conformance to [Clause 3.3.3](#).

Where luminance measurements are required, the information in [Clauses E.4.2](#) and [E.4.3](#) are provided for the guidance of the person taking the measurements and the interpretation of those measurements.

E.4.2 Direction of measurement

The luminance should be measured from all assessment planes and roads where the luminous surface is visible.

E.4.3 Factors that influence the uncertainty of the results

E.4.3.1 General

On-site measurements are subject to many variables that could impact the measured values.

These include, but should not be limited to- extraneous light. Where practicable the luminance produced by the extraneous light should be subtracted to obtain the luminance of the object of interest.

E.4.3.2 Calibration of the luminance meter

The luminance meter should be calibrated for the following:

- (i) Accuracy.
- (ii) Linearity.
- (iii) Spectral response calibration.

Corrections should be made for all of the above using the calibration for the meter or included in the uncertainty estimate of the measurement.

E.4.3.3 Meter acceptance angle

The acceptance angle of the meter should be smaller than the portion required to be measured.

For internally illuminated, diffuse signs, the area of measurement should cover a large area of the sign, or several representative points should be averaged.

The measurements should be taken close to perpendicular to the surface being measured or from the observers location.

Some meters exhibit parallax error as the angle from perpendicular increases. Care should be taken where there are variations in luminance, particularly around the edge of the sign.

Where a meter can be focused the measurement should be taken from the focused image

E.4.3.4 Non-uniform signs

Where the luminance of the surface of the sign or lit object is non-uniform, average luminance shall be determined by a uniform array of circles. The circles should not extend beyond the boundary of the illuminated area.

E.4.3.5 Coloured surfaces

Where the surface colour of the object can be changed, other than repainting, the measurements should be taken as a full white surface.

Where the surface is coloured with a single fixed colour the luminance should be averaged over the surface

Where the surface has multiple colours the average luminance should be either —

- (a) the average of a series of measurements that cover a large area of the sign and include all colours; or
- (b) a weighted average in accordance with the relative areas of the particular colours.

E.4.3.6 Dimmable lighting

Where the light source is dimmable the light should be dimmed to achieve the required maximum luminance and the dimming level recorded as part of the report.

Any controls used in the initial installation are to remain operational, at the design settings, through the life of the installation.

Bibliography

AS 2560.1, *Sports lighting, Part 1: General principles*

AS 2560.2, *Sports lighting, Part 2: Sports lighting specific applications*

SA SNZ TS 1158.6, *Lighting for roads and public spaces, Part 6: Luminaires — Performance*

CIE 001-1980, *Guidelines for minimizing urban sky glow near astronomical observatories (Joint Publication IAU/CIE)*

CIE 126, *Guidelines for minimizing sky glow*

CMS Light Pollution Guidelines for Wildlife.

UN Environment Programme Convention on the Conservation of Migratory Species of Wild Animals.
Light Pollution Guidelines: UNEP/CMS/Resolution 13.5/Annex

Australian Government – Department of the Environment and Energy & Government of Western Australia, Department of Biodiversity, Conservation and Attractions. *National Light Pollution Guidelines for Wildlife Including marine turtles, seabirds and migratory shorebirds*

Further reading

CIE 150, *Guide on the Limitation of the Effects of Obtrusive Light from Outdoor Lighting Installations*

Standards Australia

Standards Australia is an independent company, limited by guarantee, which prepares and publishes most of the voluntary technical and commercial standards used in Australia. These standards are developed through an open process of consultation and consensus, in which all interested parties are invited to participate. Through a Memorandum of Understanding with the Commonwealth government, Standards Australia is recognized as Australia's peak national standards body.

Standards New Zealand

The first national Standards organization was created in New Zealand in 1932. The New Zealand Standards Executive is established under the Standards and Accreditation Act 2015 and is the national body responsible for the production of Standards.

Australian/New Zealand Standards

Under a Memorandum of Understanding between Standards Australia and Standards New Zealand, Australian/New Zealand Standards are prepared by committees of experts from industry, governments, consumers and other sectors. The requirements or recommendations contained in published Standards are a consensus of the views of representative interests and also take account of comments received from other sources. They reflect the latest scientific and industry experience. Australian/New Zealand Standards are kept under continuous review after publication and are updated regularly to take account of changing technology.

International Involvement

Standards Australia and Standards New Zealand are responsible for ensuring that the Australian and New Zealand viewpoints are considered in the formulation of international Standards and that the latest international experience is incorporated in national and Joint Standards. This role is vital in assisting local industry to compete in international markets. Both organizations are the national members of ISO (the International Organization for Standardization) and IEC (the International Electrotechnical Commission).

Visit our websites

www.standards.org.au www.standards.govt.nz



GPO Box 476 Sydney NSW 2001
Phone (02) 9237 6000
mail@standards.org.au
www.standards.org.au



PO Box 1473 Wellington 6140
Free phone 0800 782 632
enquiries@standards.govt.nz
www.standards.govt.nz